

## **BEFORE USING THE PRODUCT, BE SURE TO READ THE FOLLOWING:**

- **Perform work in accordance with the instructions herein stated.**

Instructions for work are explained by paying attention to the aspect of accident prevention. Failing to perform work as per the instructions can cause accidents. In the case where only those who have technical expertise should perform the work to avoid hazardous situation, the instructions herein state that the technical personnel should perform such work.
- **Always turn off the power before working on the machine.**

Be sure to turn off the power and unplug the power cable before carrying out any work that requires direct contact with the interior of the product. If the work is to be performed in the power-on status, this manual always states so.
- **Be sure to ground the earth terminal.**

This product is equipped with the earth terminal. When installing the product, make sure that the earth wire is grounded, and connect the terminal to the wire. Unless the product is grounded appropriately, people can be subject to an electric shock. After performing repair, etc. for the control equipment, ensure that the earth wire is firmly connected to the control equipment.
- **Ensure that the power supply used is equipped with an earth leakage breaker.**

Using a power supply which is not equipped with the earth leakage breaker can cause a fire when earth leakage occurs.
- **Specification changes not designated by DARTSLIVE are not allowed.**

The parts of the product include warning labels for safety, covers for personal protection, etc. It is very hazardous to operate the product by removing parts and/or modifying the circuits. Doing so may cause fire or electric shock. Should doors, lids and protective parts be damaged or lost, refrain from operating the product, and contact your product retailer.  
DARTSLIVE shall not be held responsible for any accidents or compensation for damage to a third party, resulting from the specifications not designated by DARTSLIVE.
- **Be sure to check for electrical specifications.**

Ensure that the product is compatible with the power supply voltage and frequency requirements of the location.  
The product has a nameplate on which electrical specifications are described.  
Using any electrical specifications different from the designated specifications can cause a fire and an electric shock.
- **Install and operate the product in places where appropriate lighting is available, allowing warning labels to be clearly read.**

To ensure safety for the customers, labels and printed instructions describing potentially hazardous situations are applied to places where accidents can be caused. Ensure that where the product is operated has sufficient lighting allowing the warnings to be read. If any label is peeled off, apply it again immediately. Please place an order with your product retailer.
- **Be sure to adjust the monitor properly.**

Do not operate the product leaving on-screen flickering or blurring as it is. Using the product with the monitor not properly adjusted may cause dizziness or a headache to the players and the people around them.

- **When transporting or reselling this product, be sure to attach this manual to the product.**
- Even in the case where commercially available monitors and printers are used in this product, only the contents relating to this product are explained herein. Some commercially available equipment have functions and reactions not stated in this manual. Read this manual together with the specific instruction manual of such equipment.
- Descriptions herein contained may be subject to improvement changes without notice.
- The contents described herein are fully prepared with due care. However, should any question arise or errors be found, please contact your product retailer.

### **INSPECTIONS IMMEDIATELY AFTER TRANSPORTING THE PRODUCT TO THE LOCATION**

Normally, at the time of shipment, DARTSLIVE products are in a status allowing for usage immediately after transporting to the location. Nevertheless, an irregular situation may occur during transportation.

Before turning on the power, check the following points to ensure that the product has been transported in a satisfactory status.

- Are there any dented portions or defects (cuts, etc.) on the package or external surfaces of the cabinet?
- Are there any damage to the adjuster or caster?
- Are the power supply voltage and frequency compatible with the power supply specifications of the installation location?
- Are all wiring connectors properly and securely connected?  
(The connectors will not fit unless they are in the correct orientation. Do not push them forcibly.)
- Does power cable have any cuts or dents on it?
- Are all accessories available?
- Do the doors and lids open with the included key? Do the doors and lids close firmly?

## ABOUT THIS INSTRUCTION MANUAL

This manual provides information on the operation of the software of this product DARTSLIVE3 and explains it in detail. Note that the shapes illustrated in the photos and pictures in this manual may be different from the actual unit.

This manual is intended for owners, administrators, and operators of this product. Read this manual carefully and fully understand the contents before using the product.

For information on the mechanical and hardware maintenance, refer to another document, "INSTRUCTION MANUAL" .

If you cannot achieve proper functions, contact the retailer. Non-technical personnel should never touch the internal system.

In this manual, important information not extending to personal injury or material damages are described using the term "important" and icons (symbols) shown later, and enclosed in bold frame.

\* Descriptions herein contained may be subject to improvement changes without notice.

## Definition of Site Maintenance Personnel or Serviceman

### **WARNING**

Procedures not described in this manual or marked as to be carried out by “Site Maintenance Personnel” or “Serviceman” should not be carried out by personnel without the necessary knowledge and skills. Work carried out by unqualified persons may cause serious accidents, including electrocution. For safety reason, if there is no one with knowledge or skill, ask your product retailer to carry out necessary operation.

Part replacement, maintenance and inspection, and handling of abnormalities should be performed by Site Maintenance Personnel or Serviceman. This manual instructs especially dangerous work to be performed by Serviceman with expert knowledge. Site Maintenance Personnel and Serviceman are defined in the manual as below.

#### **Site Maintenance Personnel**

Person who has experience of maintenance of amusement machines, vending machines, and other equipment. Under the management of the owner and operator of this product, the person engages in the maintenance of equipment through installation, maintenance and inspection, and replacing consumable parts on a daily basis in amusement facility or in the shop.

#### **Activities of Site Maintenance Personnel**

Installation, maintenance, and inspection of amusement machines and vending machines, as well as replacement of units and consumable parts thereof.

#### **Serviceman**



Person who engages in design, manufacture, inspection, and maintenance services of equipment at amusement machine manufacturers. Person with expertise in electricity, electronics and mechanical engineering equal to or higher than those of graduates from technical high schools, and engaging in maintenance and management as well as repair of amusement equipment on a daily basis.

#### **Activities of Serviceman**





Installation of amusement machines and vending machines; repair and adjustment of electric, electronic and mechanical parts.

## Warning Signs

Make sure you fully understand the meaning of and notes on the warning signs indicated on this manual and the cabinet, and operate the product in proper and safe manner. Explanations that require particular attentions are classified and specified as DANGER, WARNING, or CAUTION, depending on severity of the potential hazard.

 <b>DANGER</b>	Indicates that mishandling the product by disregarding this pictograph will cause severe injury or death.
 <b>WARNING</b>	Indicates that mishandling the product by disregarding this warning will cause a potentially hazardous situation which can result in death or serious injury.
 <b>CAUTION</b>	Indicates that mishandling the product by disregarding this caution will cause a slight hazardous situation which can result in personal injury and/or material damage.

For the safe usage of the product, the following pictographs are used:

	Indicates "Electric Shock Hazard." It indicates the possibility of electric shock under certain conditions.
	Indicates "High Temperature Hazard." It indicates the possibility of injury from high temperature under certain conditions.
	Indicates "Hand Hazard." It indicates the possibility of injury caused by a finger or hand being caught in a door or the like.
	Indicates "Prohibition." It indicates what should not be done when handling the product.
	Indicates a "Protective Earth Terminal." Before operating the equipment, be sure to connect it to the ground.

In this manual, information that are important but not leading to personal injury or material damage are indicated with the following pictographs.

 <b>IMPORTANT</b>	It indicates important matters upon installation, operation, and maintenance and inspection of the product.
--	---

# TABLE OF CONTENTS

<b>BEFORE USING THE PRODUCT, BE SURE TO READ THE FOLLOWING:</b>	i
<b>ABOUT THIS INSTRUCTION MANUAL</b>	iii
Definition of Site Maintenance Personnel or Serviceman	iv
Warning Signs	v
<b>TABLE OF CONTENTS</b>	vi
<b>1 Overview</b>	1
1 - 1 Name of Parts	1
1 - 2 Overview	2
1 - 3 Components	3
<b>2 How to Play</b>	4
2 - 1 How to Operate	4
■ 2 - 1 - 1 Procedure to Start a Game	4
2 - 2 Using IC Card	5
■ 2 - 2 - 1 IC Card	5
■ 2 - 2 - 2 Overview of IC Card System	5
■ 2 - 2 - 3 Handling IC Card	5
■ 2 - 2 - 4 Removing IC Card	6
■ 2 - 2 - 5 Checking Data on IC Card	7
■ 2 - 2 - 6 Registering Home Shop with IC Card	7
■ 2 - 2 - 7 Rating and Flight	7
2 - 3 Help	8
2 - 4 Game Settings and Optional Game Settings	9
■ 2 - 4 - 1 Selecting Game	9
■ 2 - 4 - 2 Selecting Number of Players	9
■ 2 - 4 - 3 Optional Game Settings	10
■ 2 - 4 - 4 Handicap Setting	11
2 - 5 Game Menu	12
■ 2 - 5 - 1 Game Menu	12
■ 2 - 5 - 2 Darts Position Correction in Game Result	13
■ 2 - 5 - 3 Darts Position Correction in MEDLEY Leg Result	13
<b>3 Preparation for Starting up Online</b>	14
3 - 1 Connecting to Network / Normal Connection	15
3 - 2 Connecting Multiple Units to Network / Using HUB	16
3 - 3 Checking Connection Status with Router	17
<b>4 Starting up New Machine Online (Initial Setup)</b>	19
4 - 1 What is Activation?	20

4 - 2	Initial Setup / Activation of New Machine	21
4 - 3	Activation for Taking Over Registration (From Old I/O Board to New I/O Board)	23
<b>5</b>	<b>Maintenance Menu</b>	<b>25</b>
5 - 1	Device Settings	27
■ 5 - 1 - 1	Monitor Settings	27
■ 5 - 1 - 2	Select Camera	28
■ 5 - 1 - 3	Select Sensor	29
5 - 1 - 3 - 1	Target Sensor	29
5 - 1 - 3 - 2	Impact Sensor	30
5 - 1 - 3 - 3	Speed Sensor	31
5 - 1 - 3 - 4	Card Reader Sensor	33
■ 5 - 1 - 4	Target	33
■ 5 - 1 - 5	Light	34
5 - 1 - 5 - 1	Side LED	35
5 - 1 - 5 - 2	Standing Navi LED	36
5 - 1 - 5 - 3	Card Reader LED	36
5 - 1 - 5 - 4	Number LED	37
5 - 1 - 5 - 5	Initialize all LED Brightness Settings	37
■ 5 - 1 - 6	Sound	37
5 - 2	Coin Credit Administration	38
■ 5 - 2 - 1	Counter Management	38
5 - 2 - 1 - 1	Counter by Credit	39
5 - 2 - 1 - 2	Counter by Game	39
5 - 2 - 1 - 3	Reset All Counter Administration Data	40
■ 5 - 2 - 2	Insert Coin Settings	40
■ 5 - 2 - 3	Coin Chute Credit / Free Play Settings	41
■ 5 - 2 - 4	Settings for Regular Game Credit	41
■ 5 - 2 - 5	Happy Hour Credit Settings / Setting Time	41
5 - 2 - 5 - 1	Game Credit Settings	42
5 - 2 - 5 - 2	Time Settings	42
5 - 3	Game Settings	43
■ 5 - 3 - 1	Settings by Category / by Game	43
■ 5 - 3 - 2	Basic Settings	44
5 - 4	Advertise Settings	44
5 - 5	Language Settings	44
5 - 6	Network Settings	44
■ 5 - 6 - 1	Network Test	45

	■ 5 - 6 - 2 Online Settings	45
	5 - 6 - 2 - 1 Change Registered Shops	45
	5 - 6 - 2 - 2 Cancel Network Service	46
	<b>5 - 7 Machine Info</b>	47
<b>6</b>	<b>Troubleshooting</b>	48
	<b>6 - 1 Overview of Network</b>	50
	■ 6 - 1 - 1 Network Structure	50
	■ 6 - 1 - 2 Supplemental Terminology	50
	■ 6 - 1 - 3 Network Operation Status	51
	<b>6 - 2 Network Trouble</b>	52
	■ 6 - 2 - 1 When it Says OFFLINE	52
	■ 6 - 2 - 2 When it Says ERROR	53

\* For better service, the illustrations in the manual may be different from those displayed on the machine.



# 1 Overview

For details on the dart machine other than software, such as cabinets and components, see another document, "DARTSLIVE3 INSTRUCTION MANUAL".

## 1 - 1 Name of Parts

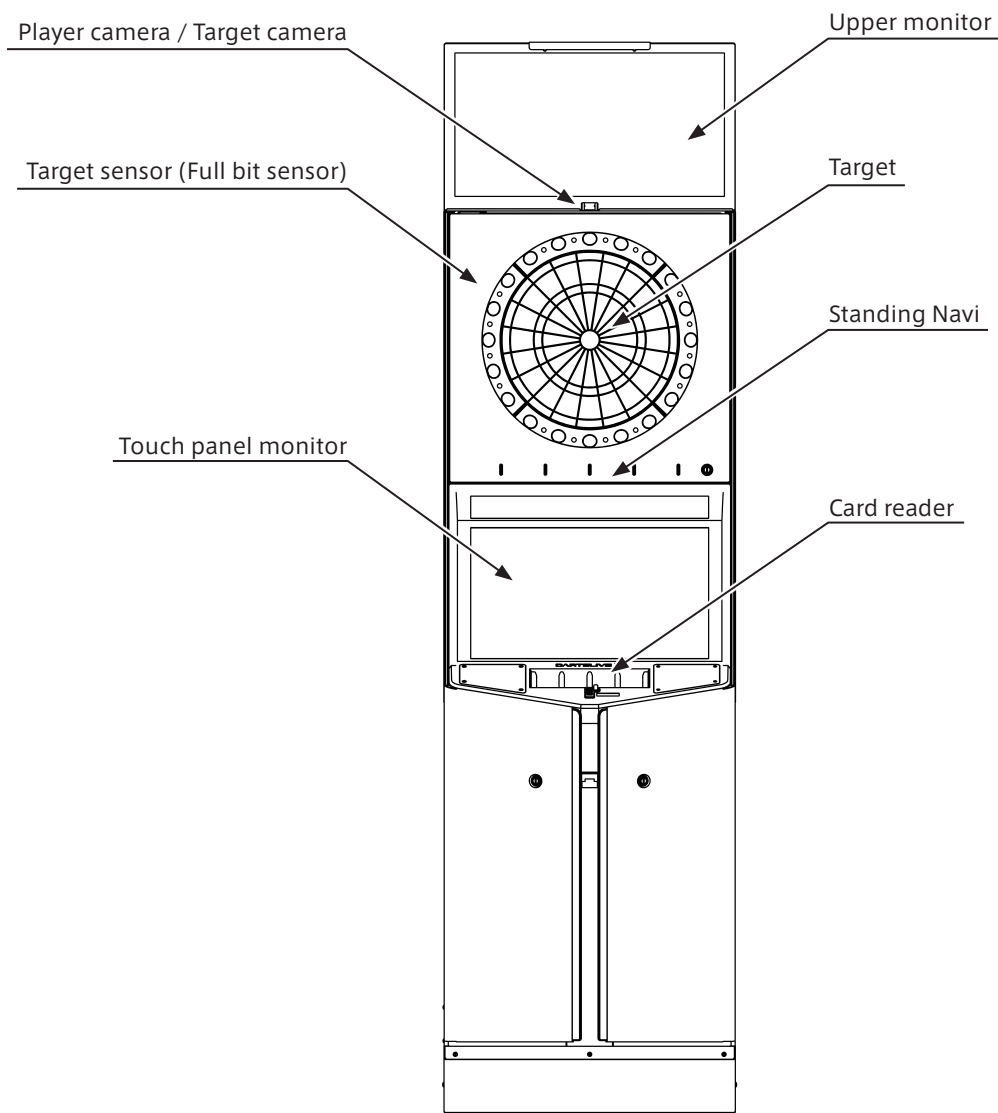

1 - 1 Figure 01

## 1 - 2 Overview

"DARTSLIVE3" has a function to interconnect shops (location where dart machine is installed), DARTSLIVE CARD (hereinafter, IC card), customers (mobile phones and PCs), and "TouchLive". It has elements to provide more enjoyable darts experience by using the network.

\* "TouchLive" is a touch-panel type game machine that you play at places like counter in a darts bar.

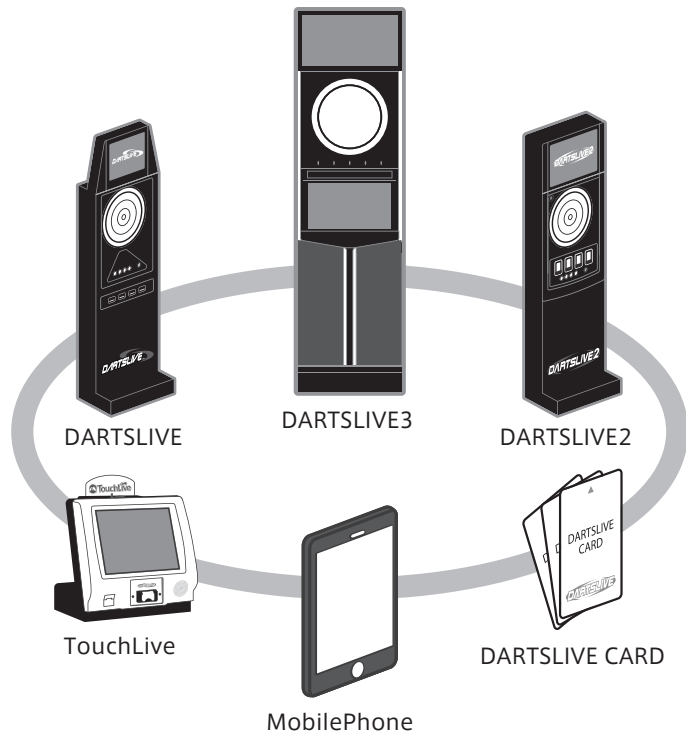

1 - 2 Fig. 01

By connecting dart machines across the nation in a network, we have provided various new games and services like the following.

- Management of individuals' scores
- Registration of home shops (making connection between the shop and the customer)
- Scores from the past
- Hosting limited time event games
- Information sharing among friends and groups

"DARTSLIVE3" offers more of new games and services.

- LIVE VIEW
- FULL BIT SENSOR
- AUTO CORK
- RANGE
- SPEED INDICATION
- STANDING NAVI
- CUSTOM DARTS
- REPLAY FUNCTION WITH APP



1 - 2 Fig. 02

## 1 - 3 Components

### **DARTSLIVE CARD (hereinafter, IC card):**

Using IC card, you can view and manage personal data stored on the "DARTSLIVE Server" (hereinafter, server). You can manage score information such as flights and ratings, stats, and number of wins and loses with one card.

In addition, you can display your name and PvP competition history on the machine. You can use this IC card in any "DARTSLIVE", "DARTSLIVE2", "DARTSLIVE3", or "TouchLive" at any shop connected to the network.

\* Note that play data will not be updated on the machines not supporting the network.

It has functions in conjunction with the services on the network (PC and mobile phone), such as viewing the transition of scores, exchanging information with group members, managing ranking within the group, and registering the shop you belong that allows you to connect with the shop.

DARTSLIVE Official Website: <http://www.dartslive.com/>

You can access the site from all connected terminals such as PC and mobile phone.

If you have iOS or Android device, you can access it from the DARTSLIVE APP.



1 - 3 Fig. 01

1

2

3

4

5

6

# 2 How to Play

## 2 - 1 How to Operate

You can select the buttons on the screen by touching it.

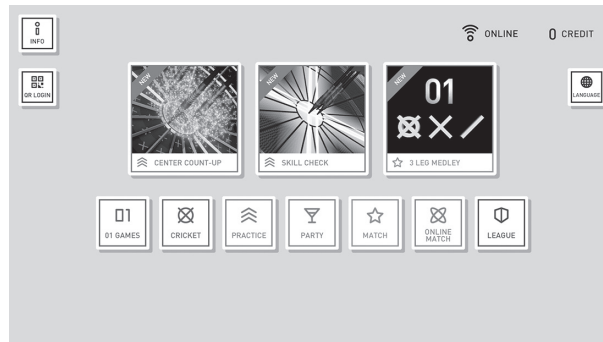

2 - 1 Fig. 01

### ■ 2 - 1 - 1 Procedure to Start a Game

STEP  
1

Insert the IC card into the card reader. To play doubles, stack two cards together and insert them into one reader.  
If you don't use IC card, skip this procedure.

STEP  
2

On the home menu screen, select the category of the game you want to play. Select the game, select the number of players, and start the game with the start button.  
\* Some games have restriction on number of players.

STEP  
3

Required credit is shown at the center of the screen. Insert the required number of coins.  
You can insert coins at any stage of the operation.

### ■ 2 - 2 - 1 IC Card

- If you insert IC card into the card reader to use the unit, it will store the player's flight, stats, and the result of play on the server. In addition, you can register and authenticate various data in cooperation with the client machine (hereinafter, machine).
- You can check data by accessing the member site in "DARTSLIVE" website (from PC or mobile phone).  
DARTSLIVE Official Website: <http://www.dartslive.com/>  
If you have iOS or Android device, you can access it from the DARTSLIVE APP.
- By inserting the card into the card reader before you start a game, it will automatically access the database and record the results and score of the game.

### ■ 2 - 2 - 2 Overview of IC Card System

- The system accesses the server and display the registered name as "player name" on the screen.
- If no name has been registered, it displays "NO NAME + last 4 digits of the access code". Access code is on the back of the card.
- You can view the score data stored on the server.
- On the machine, you can register the shop you go to frequently as your "home shop". For details, see "2-2-6 Registering Home Shop with IC Card".

\* Performance such as stats and flights are rated according to the standards of "DARTSLIVE".

### ■ 2 - 2 - 3 Handling IC Card

- You cannot use IC cards not sold at the shops.  
You can use the same IC card for "DARTSLIVE", "DARTSLIVE2", "DARTSLIVE3", and "TouchLive" operating online.
- Insert the card before you reach the screen where you select the number of players. The card will not be recognized if you inserted it when you are on that or later screens. For details, see "2-4-2 Selecting Number of Players".
- After the game has started, do not remove the IC card until the game is over.
- Even if the IC card was recognized correctly, the result of the game may not always be reflected on the server depending on the status of the network connection. We don't guarantee the information in such cases.
- You can insert up to two IC cards into one card reader at the same time. (When playing doubles.)
- IC cards are precision instruments. Keep them away from magnets. Do not bend or wet them.
- When stored information is damaged or lost, we don't recover them and we don't offer warranty or refund.
- You can transfer data for a lost card into another unused IC card.  
Follow the procedure on the website at <http://www.dartslive.com/> from PC or mobile phone.  
If you have iOS or Android device, you can execute the procedure also in the DARTSLIVE APP.

## SINGLES

1 Insert the cards into the slot at the top of the card reader. There are four slots to insert IC card. They can support up to eight cards by stacking two cards together.

2 In singles mode, they are P1, P2, P3, and P4 in order from the left. When the machine recognized the IC card, the name of the player appears at the bottom of the screen.

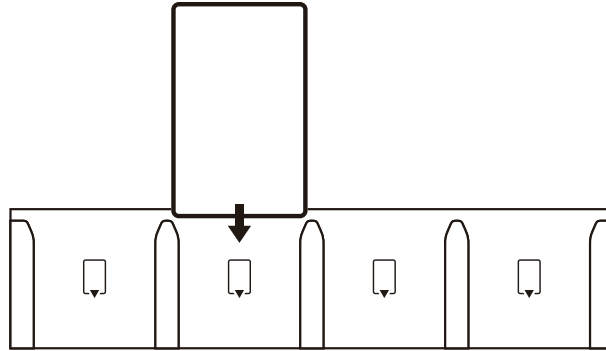

2 - 2 - 3 Fig. 01

## DOUBLES

3 When you insert two IC cards stacked together, it switches to doubles mode. The names of the players appear at the bottom of the screen in the same manner as in the singles mode.

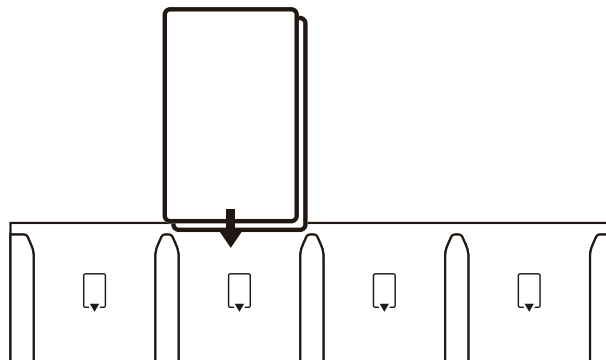

2 - 2 - 3 Fig. 02

### ■ 2 - 2 - 4 Removing IC Card

4 Pull out the IC card straight up from the card reader. If you don't pull it straight up, you may damage the IC card.

During the game, do not pull them out until the game ends.

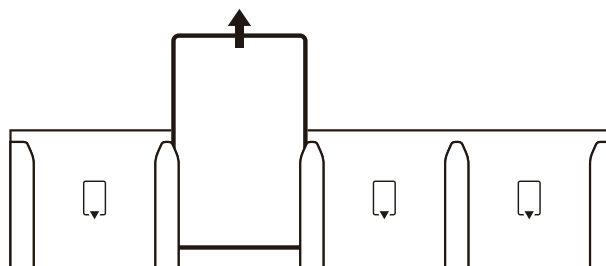

2 - 2 - 4 Fig. 01

### ■ 2 - 2 - 5 Checking Data on IC Card

You can check the data by inserting IC card and selecting "CARD DATA" after "INFO" on the home menu. The following data stored on the server are available: nickname, name, home shop, rating, flight, stats, RANGE (mm), CORK (mm), and data for DARTSLIVE APP Play Data.

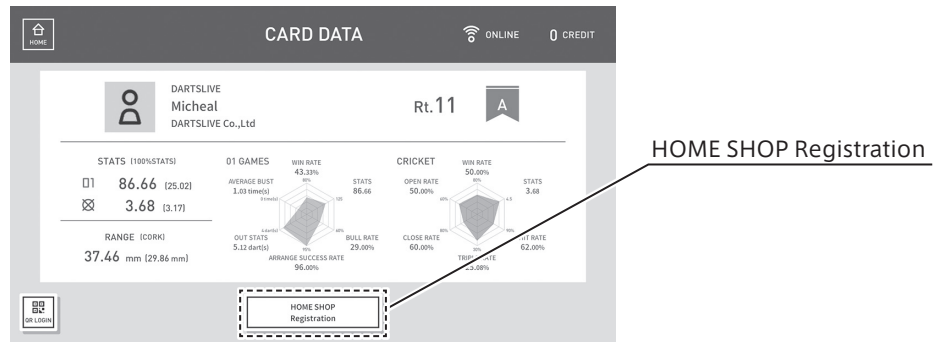

2 - 2 - 5 Fig. 01

### ■ 2 - 2 - 6 HOME SHOP Registration with IC Card

You can register your home shop by tapping HOME SHOP Registration, regardless of the number of IC cards.

**Home Shop Registration :** HOME SHOP Registration you are currently playing at as home shop by tapping Register Home Shop. It changes the home shop of all IC cards inserted in the card readers 1 to 4 at the same time.

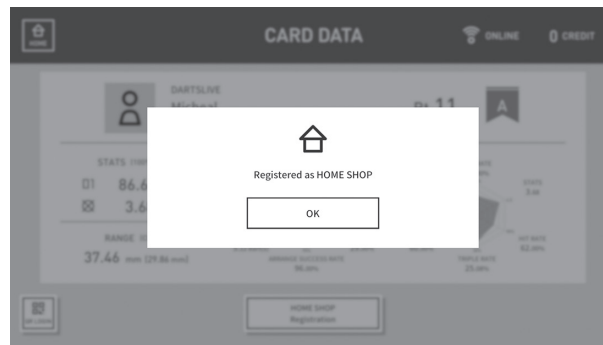

2 - 2 - 6 Fig. 01

### ■ 2 - 2 - 7 Rating and Flight

By inserting IC card and playing at least ten games of 01 game and STANDARD CRICKET in PvP with two or more players, personal rating and flight will be calculated. Ratings are required for participating in the tournaments and for automatically applying for handicap.

### ■ Description of Games

Images of the games have magnifying glass icon.  
When you touch the image, the description of the game appears.

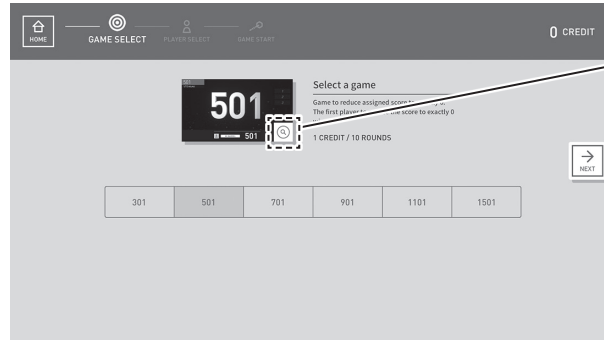

Magnifying glass icon

2 - 3 Fig. 01

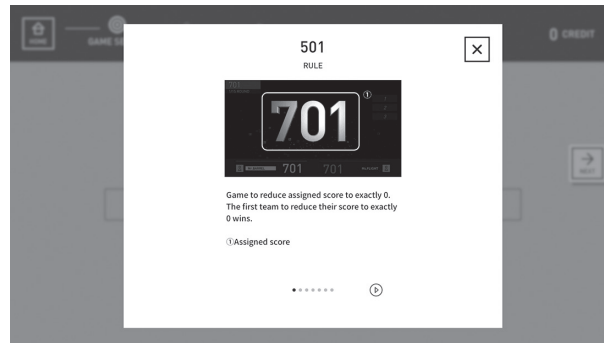

2 - 3 Fig. 02



## 2 - 4 Game Settings and Game Option Setting

### ■ 2 - 4 - 1 Selecting Game

When you select a category in the home menu, the game selection screen appears. Select the game you want to play and tap NEXT. Swiping the screen gives you the same effect as tapping NEXT.

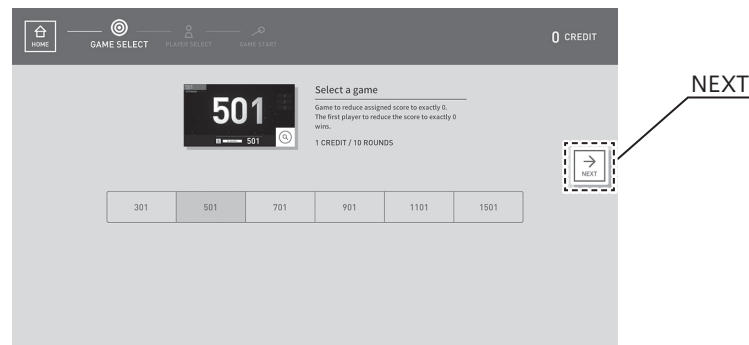

2 - 4 - 1 Fig. 01

### ■ 2 - 4 - 2 Selecting Number of Players

Select the number of players. If you have not inserted two stacked IC cards in the same slot, the icon "doubles setting" appears under the player name. Tapping it will change the setting to doubles. If you want to cancel it, tap the icon "cancel doubles setting".

\* When you configured the setting for doubles, the notation of the select number of player icon will change from PLAYER to TEAM.

If you have IC card inserted and set it to doubles, "Switch first/second" button appears. You can swap the first and second by tapping the button.



2 - 4 - 2 Fig. 01

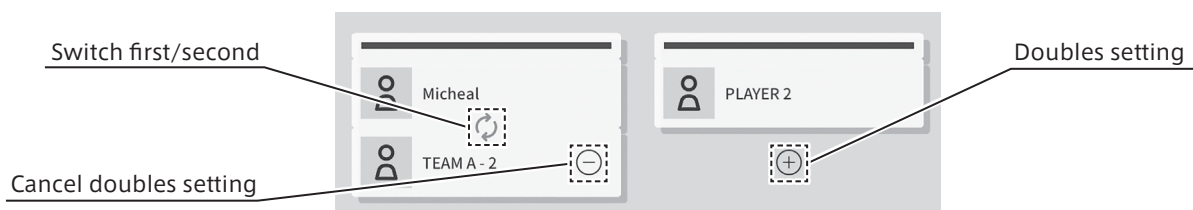

2 - 4 - 2 Fig. 02

## ■ 2 - 4 - 3 Game Option Setting

When you tap GAME OPTION, it will open the setting screen.

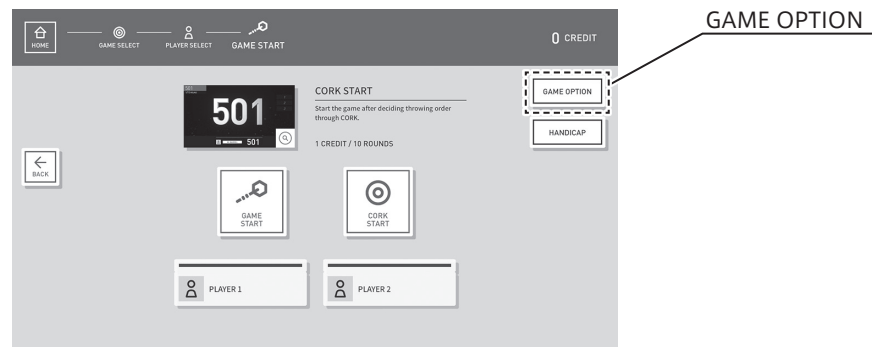

2 - 4 - 3 Fig. 01

**IN** : Specify the first target to hit in the game.

OPEN : No specific target to hit first.  
DOUBLE : Start the game with hitting a double.

**OUT** : Specify the last target to hit in the game.

OPEN : No specific target to hit at the end.  
DOUBLE : Out the game with hitting a double at the end.  
MASTER : Out the game with hitting BULL, double or triple at the end.

**BULL** : Set the points for double bull and single bull.

50/50 : 50 points for both double and single bulls.  
25/50 : 50 points for double bull, and 25 points for single bull

**CUT THROAT** : Setting available exclusively in crickets with three or more teams. In this setting, the points you get are distributed to other players and the player with the fewest points wins.

**THROWING ORDER** : Throwing order to apply in the second and later legs, available in MEDLEY.

LOSER : Loser throws first.  
ALTERNATIVE : Players alternately throw first.

**FULL LEG** : Turn it ON to play the game to the last LEG regardless of the number of wins the player has over another player.

**MANUAL CORK** : The setting available only when two players playing PVP. Setting to cork at before a game and before a CHOICE.

OFF : Play the game with AUTO CORK.  
ON : Play the game with MANUAL CORK.

## < Availability of Option Settings for Each Game >

	01	CRICKET	MEDLEY
IN	●		●
OUT	●		●
BULL	●		●
CUT THROAT		●	
THROWING ORDER			●
FULL LEG			●
MANUAL CORK	●	●	●

2 - 4 - 3 Fig. 03

\* MANUAL CORK setting is only available in PvP for two players or two teams.

### ■ 2 - 4 - 4 Handicap Setting

When you tap HANDICAP, handicap menu appears.

\* The handicap function can be selected only in PvP by two or more teams.

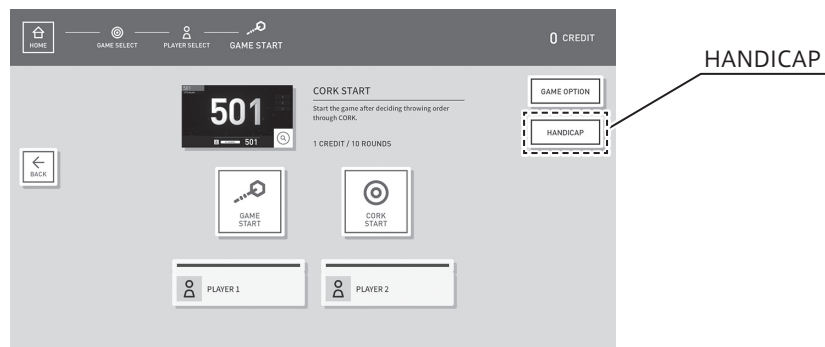

2 - 4 - 4 Fig. 01

By selecting ON, numbers are automatically reflected while IC card with calculated rating is inserted.

If no rating has been calculated or if no IC card is inserted, the rating 1 is automatically reflected.

Both players can change the number with the icons "+" and "-". Handicaps are automatically added according to the changed number.

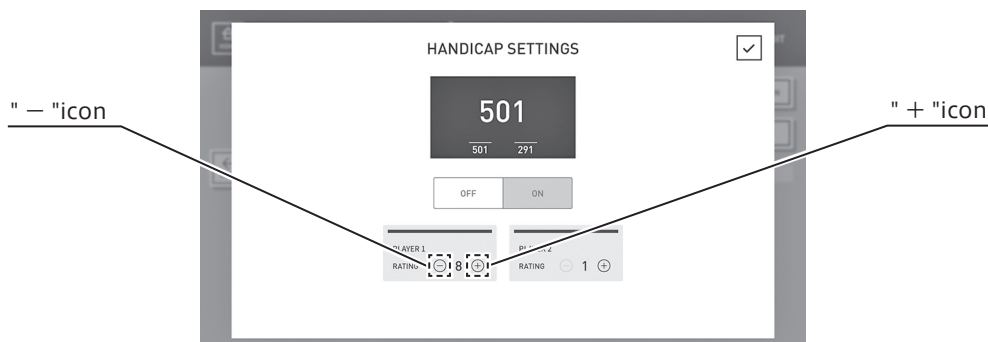

2 - 4 - 4 Fig. 02

## 2 - 5 Game Menu

When you tap the game menu button displayed on the touch screen monitor, the item window appears.



2 - 5 Fig. 01

### ■ 2 - 5 - 1 Game Menu

**Game Rules :** You can check the rules of the game you are playing.

**Back to the Prev Player :** You can invalidate the dart thrown by the player in his/her turn and make him/her throw again.  
If that player has not thrown yet, you can go back to the previous player.

**Darts Position Correction :** You can correct the position where the dart thrown hit.  
\* In some games, you may not be able to select this.

**Finish the Game :** You can end the game you are currently playing.

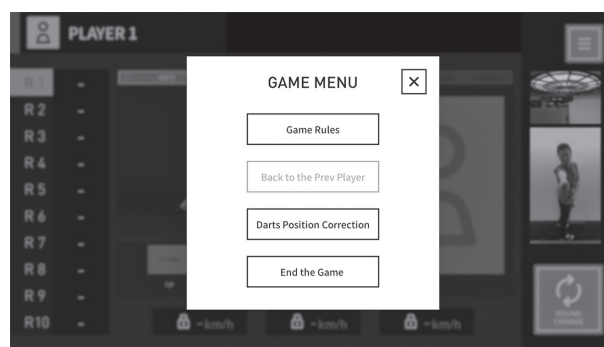

2 - 5 - 1 Fig. 01

### ■ 2 - 5 - 2 Darts Position Correction in Game Result

When you tap the result menu button displayed on the touch screen monitor, the window for Darts Position Correction function appears.

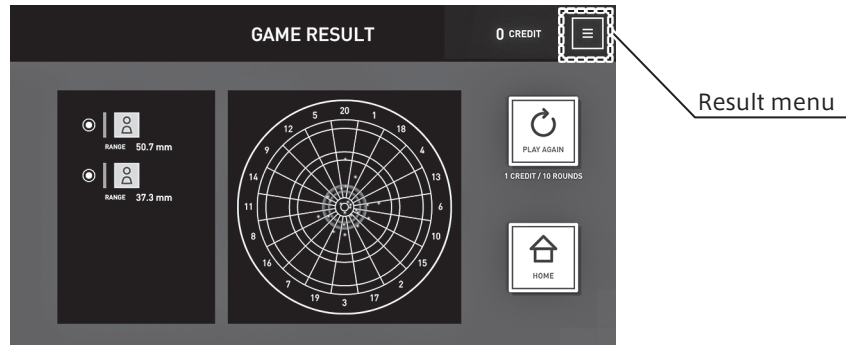

2 - 5 - 2 Fig. 01

### ■ 2 - 5 - 3 Darts Position Correction in MEDLEY LEG Result

When you tap the result menu button displayed on the touch screen monitor, the window for Darts Position Correction function appears.

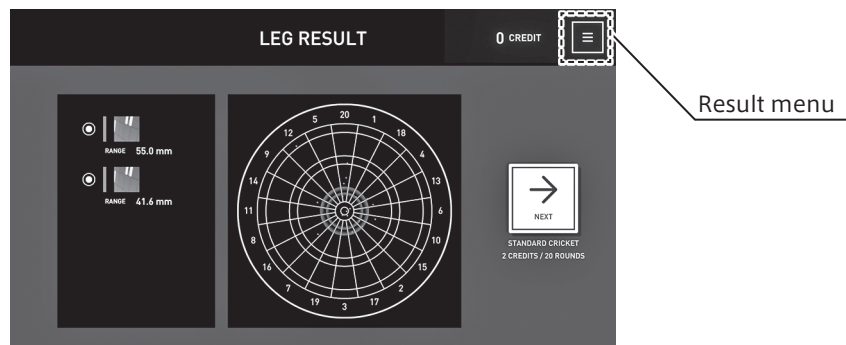

2 - 5 - 3 Fig. 01

## 3 Preparation for Starting up Online

To use DARTSLIVE3 online (using a network), you need to prepare the network environment in advance.

In addition, you need to register (application and review) the shop. Contact DARTSLIVE Co., Ltd. for details on how to register the shop.

The following items are required for starting up online. However, the description below may not apply in some cases.

**Initial construction** : Internet Network Installation

**Router(\*1), modem(\*2)** : Use the prescribed router.

**Power supply** : 4 outlets for darts machine, router and modem.

**Activation setting** : The network setting for "DARTSLIVE3" provided by the dealer.

**Hub** : Required when connecting more than one "DARTSLIVE3" machine.

(\*1) A modem is a type of network device. A modulator-demodulator. It converts digital data into audio signals and sends them onto telephone lines, or converts audio signals from telephone lines into digital data. In the case of an optical line, it is called an optical network unit.

(\*2) A router is a device connecting multiple LANs. A device installed at a branch point connecting multiple LANs and relaying data flowing on a network to other networks.

### 3 - 1 Connecting to Network / Normal Connection

This is how you connect up to four "DARTSLIVE3" to the network.

First, connect the LAN cables as shown in the figure. Turn on the power at ① and then at ②. Wait about one minute, and turn on the power at ③.

\* If you do not turn on their power in correct order, "DARTSLIVE3" will not be updated properly.

\* You can power on ③ "DARTSLIVE3" in any order.

To operate five or more DARTSLIVE3, the connection requires use of HUB. See "3-2 Connecting Multiple Units to Network / Using HUB".

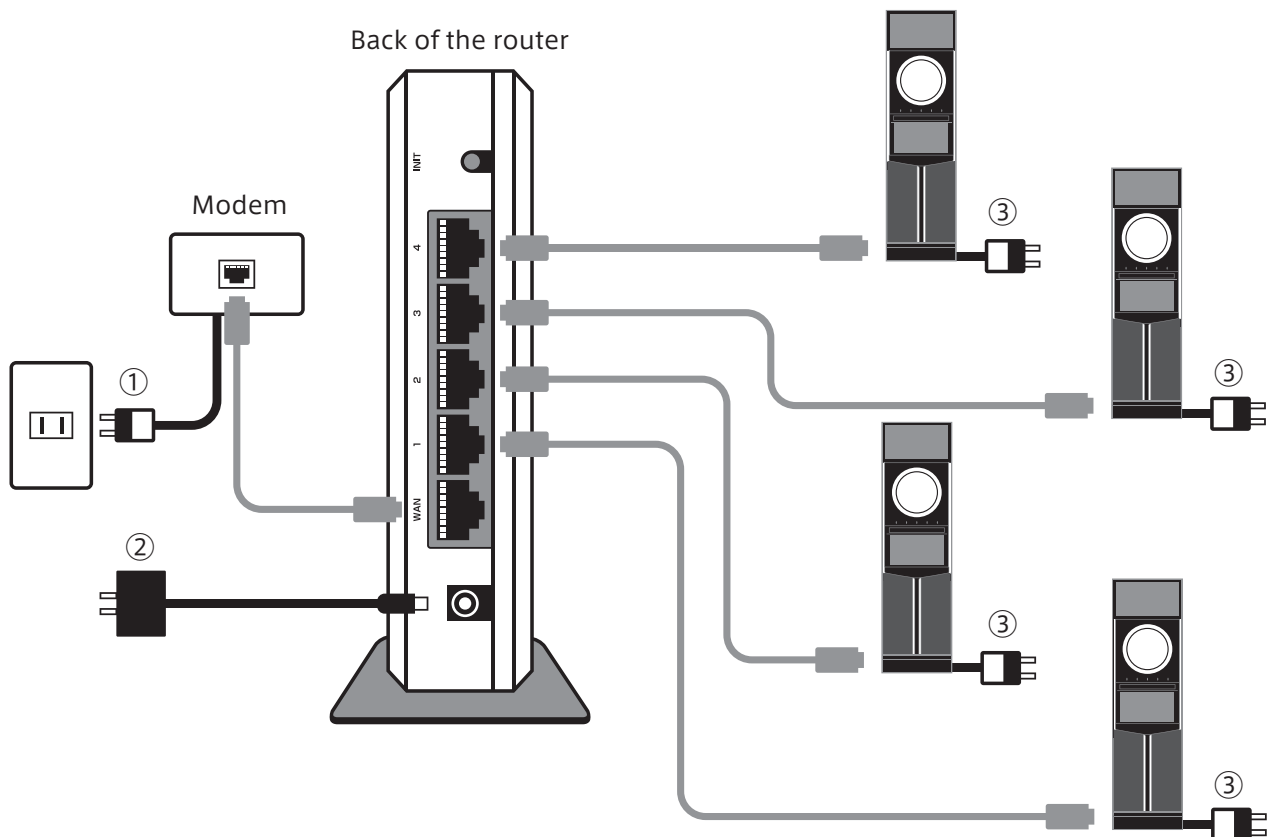

3 - 1 Fig. 01

## STOP IMPORTANT

The terms and conditions prohibits connecting devices other than "DARTSLIVE", "TouchLive", "DARTSLIVE2", and "DARTSLIVE3" to the router prepared exclusively for DARTSLIVE. Note that if other devices are connected, we do not guarantee proper connection of "DARTSLIVE", "TouchLive", "DARTSLIVE2", "DARTSLIVE3" and the router.

When connecting five or more "DARTSLIVE3", you should prepare a HUB. When using a HUB, connect the router and the HUB with a LAN cable. You will connect the router and "DARTSLIVE3" via HUB. Turn on their power in order of ①, ②, ③, and ④.

\* You can power on ④ "DARTSLIVE3" in any order.

Customers who are to connect multiple "DARTSLIVE3" should consult with DARTSLIVE Co., Ltd. When using a HUB, the connections are basically the same as in the normal setting. (See 3-1 Fig. 01)

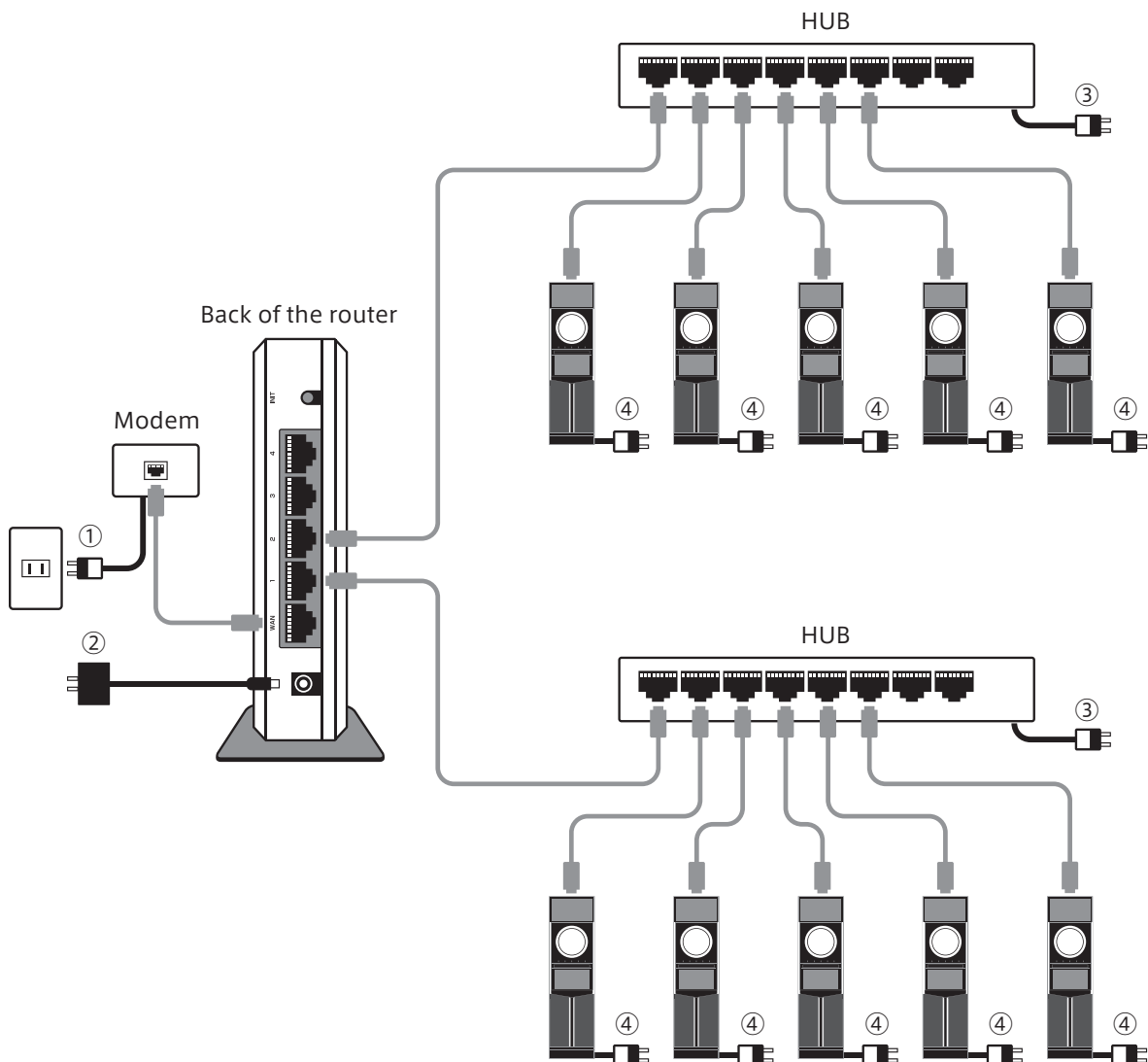

3 - 2 Fig. 01



### 3 - 3 Checking Connection Status with Router

After connecting the LAN cables and turning on the power, check the three types of LED indicators on the front of the router.

When the network is operating normally, POWER, WAN (when modem or like device is connected), and LAN (HUB) indicators will light. You may be able to identify the cause of a network failure by checking these indicators.

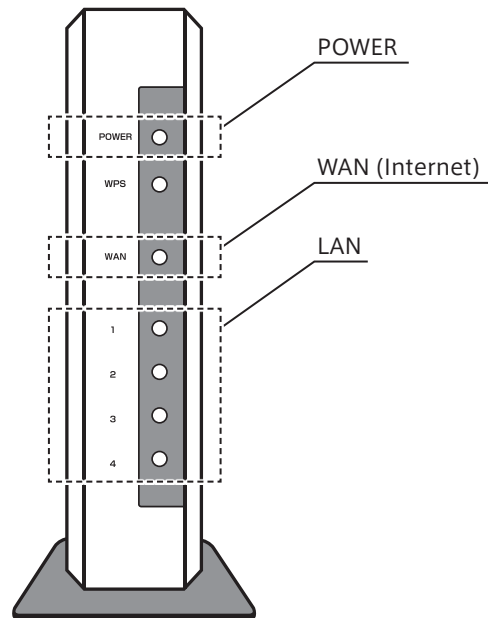

3 - 3 Fig. 01

**POWER :** It lights up when the router is powered on.  
If it is not lit up, check the power adapter.

**WAN (Internet) :** It lights up or flashes when it is connected to an internet network.  
If it does not lit up, check the connection of the LAN cable, and then condition of the network.

**LAN :** While it is connected to "DARTSLIVE3", the indicators LAN 1 to 4 lit up or blink. The numbers correspond to each of the connected "DARTSLIVE3" ① , ② , ③ and ④ .  
If it does not lit up, check the connection to "DARTSLIVE3".

### < Network Errors >

- 1 ● Screen of "DARTSLIVE3" freezes.
  - Restart DARTSLIVE3.
- 2 ● There is one unit which does not go online.
  - You may have a loose LAN cable. Check the sockets on the HUB connected to "DARTSLIVE3" or the router.
- 3 ● No "DARTSLIVE3" come online in one specific area.
  - Check the indicators on the HUB. If they are not lit, restart the HUB.
  - If the indicators are not lit, check if you are using appropriate type of LAN cable.
  - Check the connection of LAN cable between the router and HUB.
  - HUB may be freezing. Restart it.
- 4 ● All "DARTSLIVE3" in all areas do not come online.
  - Check the indicator on the router. If it is not lit, restart the router.
  - The router may be freezing. Restart it.
  - If the indicators shown in 3-3 Fig.01 are lit, it is operating normally. Refer to the instruction manual of the router for details on its indicators.
  - You may have a loose LAN cable. Check the sockets for LAN cables.
- 5
- 6

## 4 Starting up New Machine Online (Initial Setup)

### **STOP** IMPORTANT

Do not turn off the power when it is downloading data. It may cause a failure.

#### < Operation at Machine Startup >

If the machine is connected online, it checks for the latest program and data at startup. When there is a download progress bar at the bottom of the screen as shown below, it is downloading the data.



4 Fig. 01

## 4 - 1 What is Activation?

1 After connecting to the network, initial setup (activation) is required to start a new machine for the first time. Initial setup is required not only "when starting a new machine" but also "when taking over registration to a new machine due to failure or other reasons."

2 Note that the online service will start with the completion of the initial setup, and you will be charged. When a new machine or a machine with replaced I/O board is connected to the network and turned on, it opens the initial setup screen.

Refer to "3 Preparation for Starting up Online" for how to connect to the network.

3 The following three items are required for initial setup:

**Registered Dealer ID :** ID issued by DARTSLIVE Co., Ltd. at the time of dealer registration.

**Dealer PASS (PIN):** PIN issued by DARTSLIVE Co., Ltd. at the time of dealer registration.

**Registered Shop ID :** Shop ID provided to you when setting up the network connection.  
(For activation, you need Dealer ID, Dealer PASS, and Shop ID.)

4 These input information are verified in the database, and the setting completes when they are authenticated.

At the moment the setting is completed, you can start the game online.

5 "When taking over registration to a new machine due to failure or for other reason", the following items are required in addition to the above.

**ID of the machine from which registration is transferred from :**

Unique machine ID is stored on the I/O board. Machine ID is affixed to the I/O board with a sticker.

6 \* Note that registration cannot be taken over from "DARTSLIVE" to "DARTSLIVE3", "DARTSLIVE3" to "DARTSLIVE", "DARTSLIVE2" to "DARTSLIVE3", "DARTSLIVE3" to "DARTSLIVE2", "DARTSLIVE" to "DARTSLIVE2", or "DARTSLIVE2" to "DARTSLIVE".

\* The I/O board connected to "DARTSLIVE3" is exclusive I/O board for "DARTSLIVE3".It cannot be used for "DARTSLIVE", "DARTSLIVE2", or "TouchLive".

## 4 - 2 Initial Setup / Activation of New Machine

Execute procedure to register and set up a new "DARTSLIVE3" in the initial state and make it available for online use.

### STEP 1

Connect "DARTSLIVE3" to the network and power it on.

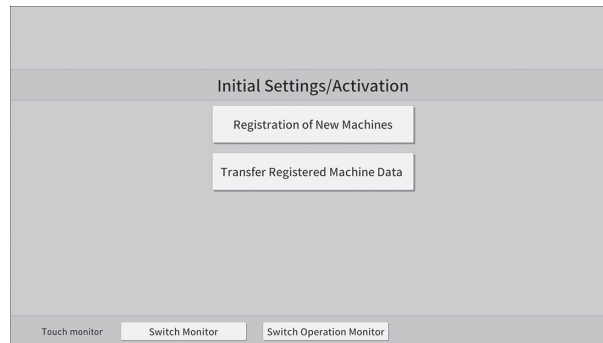

4 - 2 Fig. 01

### STEP 2

It opens the initial setup/activation screen. (4-2 Fig. 01) Select "New registration of machine ". If menu screen appears instead of the initial setup screen, you may have a problem with the network connection. See "6 Troubleshooting".

### STEP 3

One by one, enter your "Registered Dealer ID", "Registered Dealer PASS (PIN)" and "Registered Shop ID".

\* If there is an error in the input information, the message appears on the screen stating so.

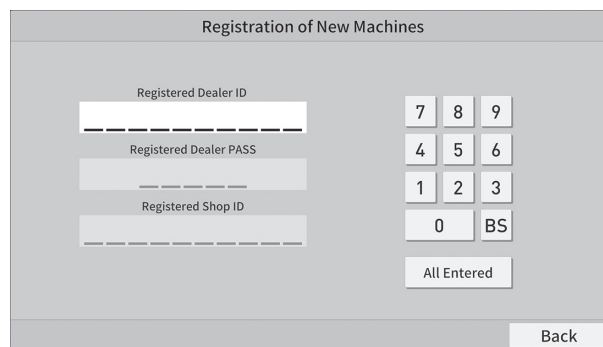

4 - 2 Fig. 02

**STEP 4**

The dealer name and shop name to register appear on the screen. Check the information to register. Tap "Yes" to complete the registration.

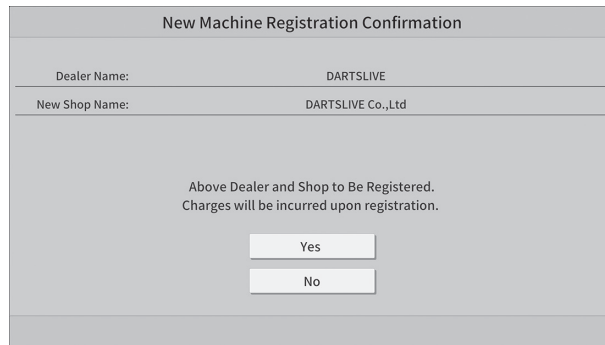

4 - 2 Fig. 03

**STEP 5**

Tap "OK" to move to the home menu in the online mode.

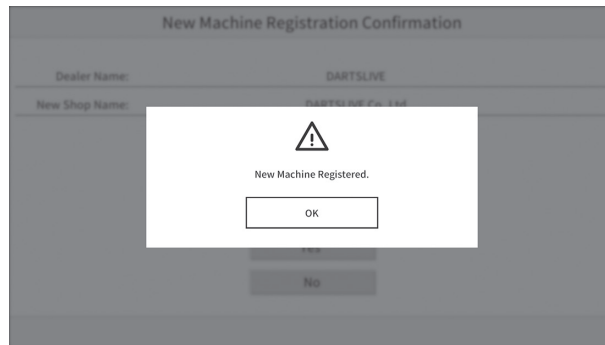

4 - 2 Fig. 04

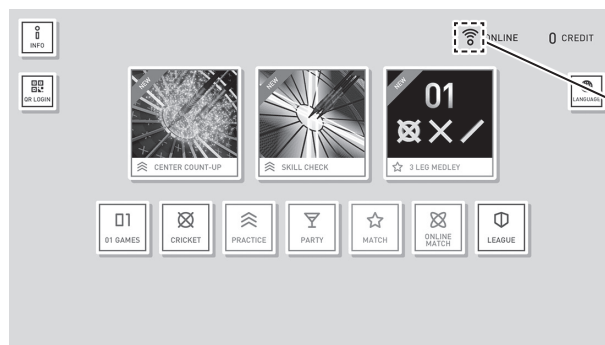

4 - 2 Fig. 05

Online indicator

## 4 - 3 Activation for Taking Over Registration (From Old I/O Board to New I/O Board)

When replacing the board with a new one due to failure or other reason, or when taking over registration from an old machine, the following procedure is required.

\* Note that registration cannot be taken over from "DARTSLIVE" to "DARTSLIVE3", "DARTSLIVE3" to "DARTSLIVE", "DARTSLIVE2" to "DARTSLIVE3", "DARTSLIVE3" to "DARTSLIVE2", "DARTSLIVE" to "DARTSLIVE2", or "DARTSLIVE2" to "DARTSLIVE", since they have different I/O boards.

**STEP**  
**1**

Connect "DARTSLIVE3" to the network and power it on.

**STEP**  
**2**

It opens the initial setup screen. (4-3 Fig. 01)

Tap "Transfer registered machine data".

If the menu screen appears instead of initial setup screen, the network may be improperly connected.

See "6 Troubleshooting".

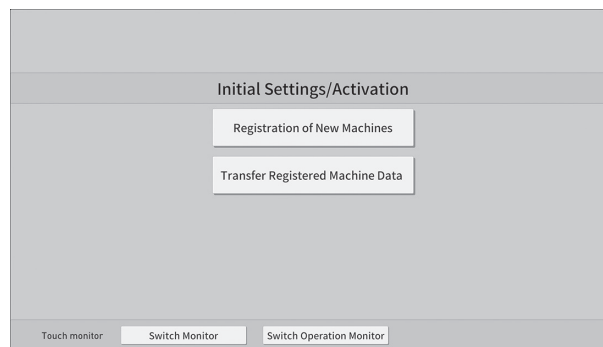

4 - 3 Fig. 01

**STEP**  
**3**

Enter all of the following: "Registered Dealer ID", "Registered Dealer PASS (PIN)", "Original Machine ID", and "Registered Shop ID". Tap "All Entered".

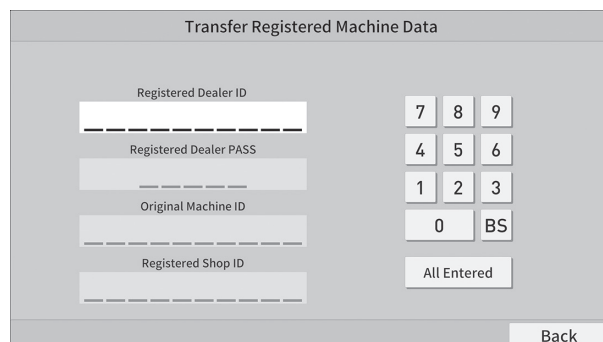

4 - 3 Fig. 02

**STEP**  
**4**

The dealer name and shop name to register appear on the screen. Check the information to register. Tap "Yes" to complete the registration.

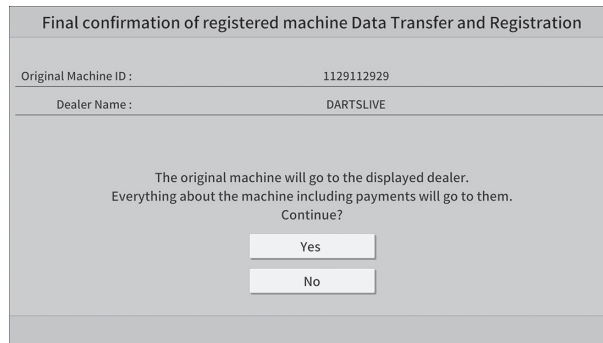

4 - 3 Fig. 03

**STEP**  
**5**

Restart the machine.

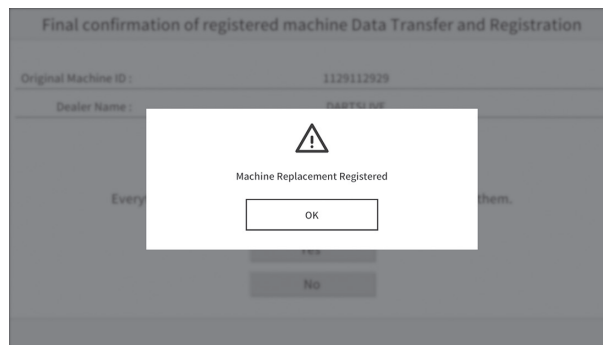

4 - 3 Fig. 04

**< When Activation Screen Does Not Appear >**

If the activation screen does not appear even though the machine has not been registered yet, the network may be connected incorrectly. If you turn on the power with the cable disconnected from the router, it starts in offline mode and you cannot perform activation registration. Contact DARTSLIVE Co., Ltd. for more detail.

**< To Change the Registered Setting >**

If there is a change in the information registered in the initial setup (registered dealer and registered store), change the setting with system maintenance menu. For more detail, see "5-6 Network Settings".



## 5 Maintenance Menu

### WARNING

- Do not touch any part which are not instructed. Touching a part which is not instructed may cause electric shock or short circuit.
- Inspection inside the energized machine should be performed by Site Maintenance Personnel or technician. If you do not have the knowledge and skills, never perform the inspection. It may cause electric shock or short circuit.

### IMPORTANT

- When a customer is playing on another dart machine connected to the network, you can still operate the maintenance menu with this dart machine.
- You can change setting for each machine, such as various game settings and Happy Hour Credit setting. Be careful when installing dart machines with different price settings in the same shop.
- Changes to the settings in the maintenance menu will take effect when you tap "End" after making the changes.
- The I/O board connected to "DARTSLIVE3" is exclusive for "DARTSLIVE3". It cannot be used for "DARTSLIVE2", "DARTSLIVE", or "TouchLive".

Operations of the system maintenance menu include the operations inside the machine while power is on.

Pay more than enough cautions as careless work may result in electric shock or short circuit.

## Launching the Maintenance Menu

Stand at the front of the cabinet. Open the right side door and press "TEST" button.

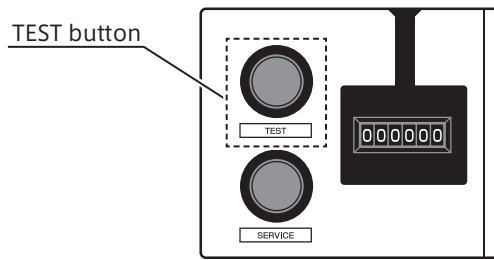

5 Fig. 01

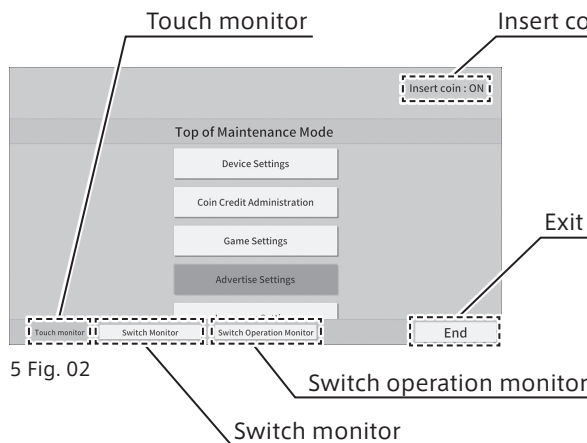

5 Fig. 02

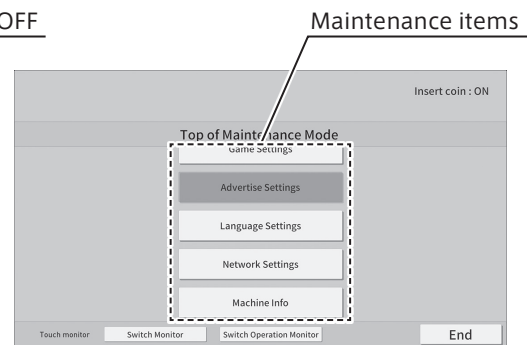

5 Fig. 03

**Insert coin ON/OFF :** It indicates that the Insert Coin Settings is ON.  
It indicates that the Insert Coin Settings is OFF.  
When the Free Play Settings is ON, "Free play" is displayed.  
To change the insert coin settings, refer to "5-2 Coin Credit Administration".

**Touch monitor :** It indicates that the screen you are operating is the touch screen monitor.  
If it is the upper monitor, change it with Switch monitor.

**Switch Monitor :** It swaps the content displayed on the upper monitor with the content displayed on the touch screen monitor.

**Switch Operation Monitor :** Tap this button to use the monitor you are touching as the main monitor.

**Exit :** Tap this button to reflect the changes and exit the maintenance mode.

**Maintenance Items :** You can adjust settings for various maintenance modes.

- Device settings - Refer to "5-1 Device Settings".
- Coin Credit Administration - Refer to "5-2 Coin Credit Administration".
- Game Settings - Refer to "5-3 Game Settings".
- Advertise Settings - Refer to "5-4 Advertise Settings".
- Language Settings - Refer to "5-5 Language Settings".
- Network Settings - Refer to "5-6 Network Settings".
- Machine info - Refer to "5-7 Machine Info".

## 5 - 1 Device Settings

You can perform setting and adjustment on the devices.

- Monitor - Refer to "5-1-1 Monitor Settings".
- Camera - Refer to "5-1-2 Select Camera".
- Sensor - Refer to "5-1-3 Select Sensor".
- Target - Refer to "5-1-4 Target".
- Light - Refer to "5-1-5 Light".
- Sound - Refer to "5-1-6 Sound".

### ■ 5 - 1 - 1 Monitor Settings

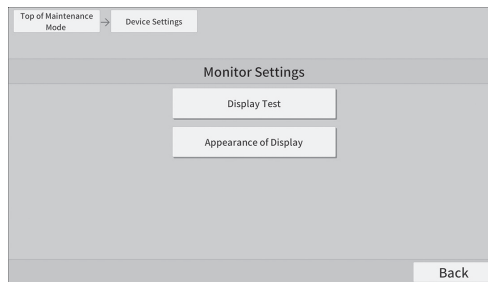

5 - 1 - 1 Fig. 01

**Display Test :** You can check the color adjustment of the upper monitor (5-1-1 Fig. 02) and the touch screen monitor (5-1-1 Fig. 03). The red, green, and blue colors are the darkest at the left end, and grow brighter in 31 levels as it moves to the right. The brightness of the monitor is normal when the white color bar is black at the left end and white at the right end.

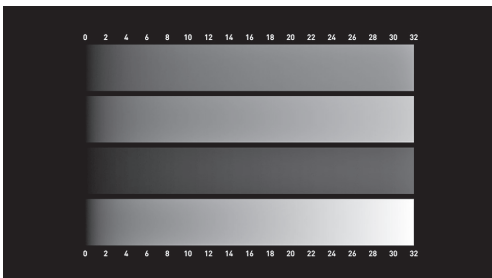

5 - 1 - 1 Fig. 02

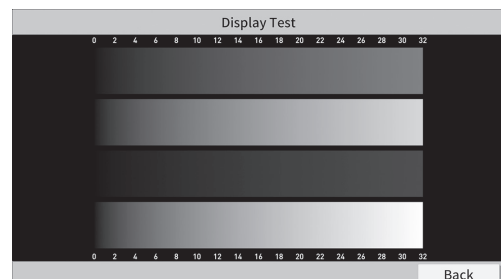

5 - 1 - 1 Fig. 03

**Appearance of Display :** You can check the size adjustment on the upper monitor (5-1-1 Fig. 04) and the touch screen monitor (5-1-1 Fig. 05).

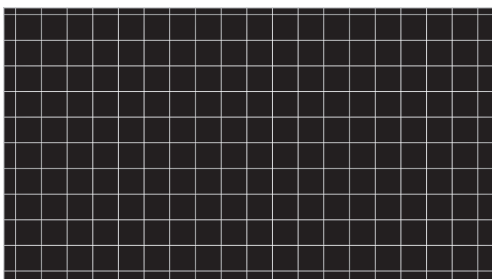

5 - 1 - 1 Fig. 04

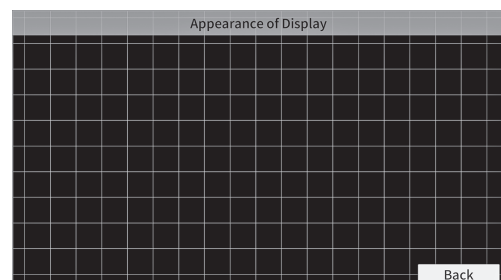

5 - 1 - 1 Fig. 05

## ■ 5 - 1 - 2 Select Camera

1

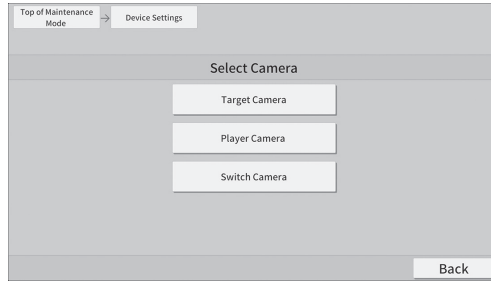

5 - 1 - 2 Fig. 01

2

3

**Target Camera :** You can check the display of the camera (5-1-2 Fig. 03) aimed at the target (the board) by performing a display test (5-1-2 Fig. 02).

4

5

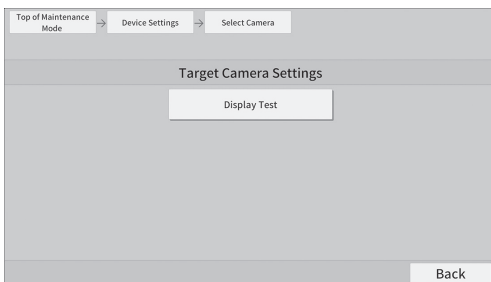

5 - 1 - 2 Fig. 02

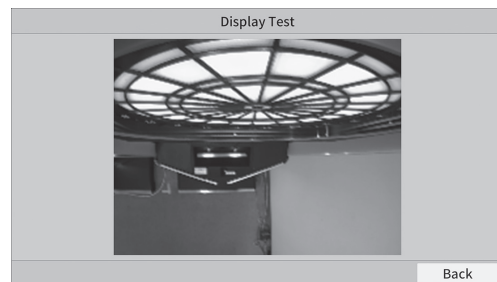

5 - 1 - 2 Fig. 03

6

**Player Camera :** You can check the display of the camera aimed at the player (5-1-2 Fig. 05) by performing a display test (5-1-2 Fig. 04).

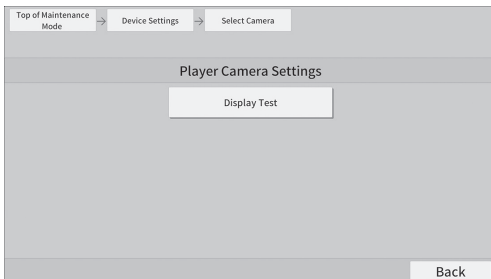

5 - 1 - 2 Fig. 04

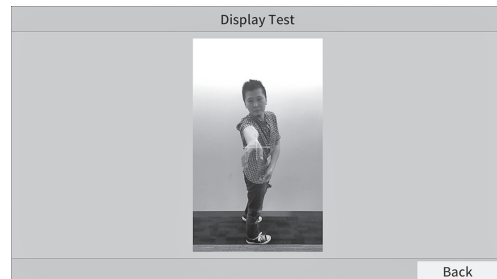

5 - 1 - 2 Fig. 05

**Switch Camera :** You can swap the target camera and player camera by tapping "Switch".

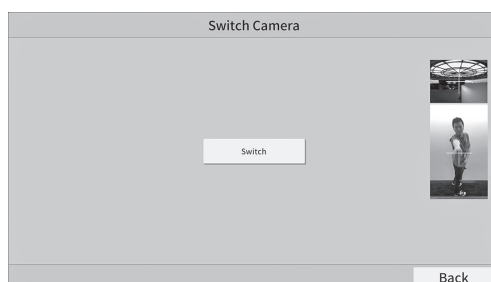

5 - 1 - 2 Fig. 06

## ■ 5 - 1 - 3 Select Sensor

You can make adjustment on the sensors.

- Target sensor - Refer to "5-1-3-1 Target Sensor".
- Impact sensor - Refer to "5-1-3-2 Impact Sensor".
- Speed sensor - Refer to "5-1-3-3 Speed Sensor".
- Card reader sensor - Refer to "5-1-3-4 Card Reader Sensor".

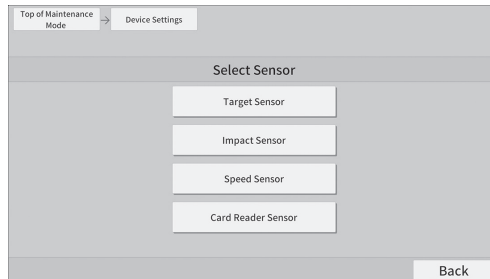

5 - 1 - 3 Fig. 01

### 5 - 1 - 3 - 1 Target Sensor

You can make adjustment on the sensor that detects where the dart hits on the target.

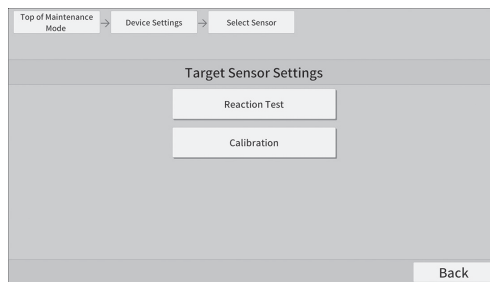

5 - 1 - 3 - 1 Fig. 01

**Reaction Test :** Perform reaction test on the target sensor.  
Follow the instructions in order to perform the test.

**Note :** Start work with nothing stuck in the target.  
Use a straight tip.  
Be sure to check with one tip.  
Do not touch the target during the check.  
When the location you are checking turns yellow, remove the tip  
and check the next location.

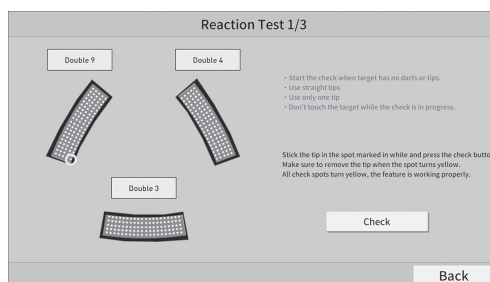

5 - 1 - 3 - 1 Fig. 02

**Calibration :** Make adjustments so that the target sensor properly sense the position where the dart hits on the target.  
Follow the instructions in order to perform the test.

**Note :** Start work with nothing stuck in the target.  
Use a straight tip.  
Be sure to check with one tip.  
Do not touch the target during the check.  
When the location you are checking turns yellow, remove the tip and check the next location.

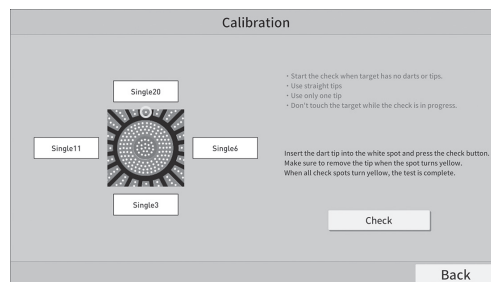

5 - 1 - 3 - 1 Fig. 03

### 5 - 1 - 3 - 2 Impact sensor

You can adjust the sensitivity of the impact sensor.  
Impact sensors are used to make judgement of outboards during the game.

**Sensitivity Adjustment :** Moving the slide bar toward MIN makes the sensors respond to small impacts.

Conversely, moving it toward MAX makes the sensors less responsive even to large impacts.

You can Initialization the slide bar to the factory setting by tapping "Initialization".

When you apply impact to the target, it displays the gauge corresponding to the impact.

At this time, the number of the sensor that is responding also lights up.

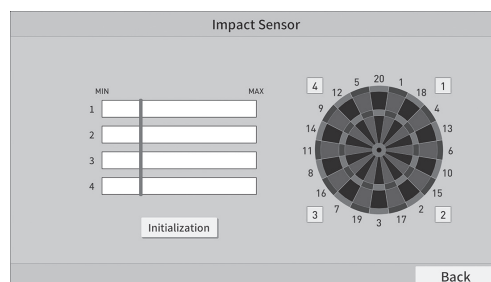

5 - 1 - 3 - 2 Fig. 01

### 5 - 1 - 3 - 3 Speed Sensor

You can conduct reaction and Machine Environment Test for the speed sensor. As the speed sensor may not respond properly depending on the environment of the shop, be sure to perform the tests.

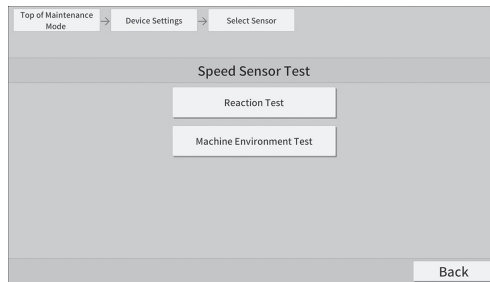

5 - 1 - 3 - 3 Fig. 01

**Response Test :** You can check if the speed sensor responds or not. If it displays the speed when the dart hits the target, it is working properly.

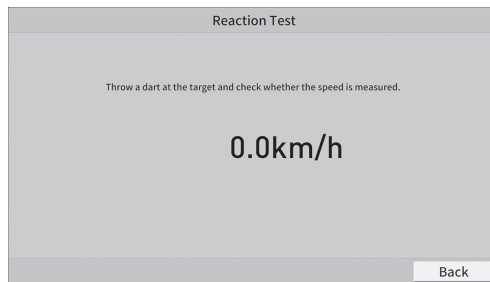

5 - 1 - 3 - 3 Fig. 02

**Machine Environment Test :** Test whether the speed sensor works properly at the shop where the DARTSLIVE3 is installed.

**STEP**  
**1**

You should run the air conditioner installed in the shop at high mode. Make sure that strong air is coming from the air conditioner before you start the test.

**STEP**  
**2**

Tap Check.

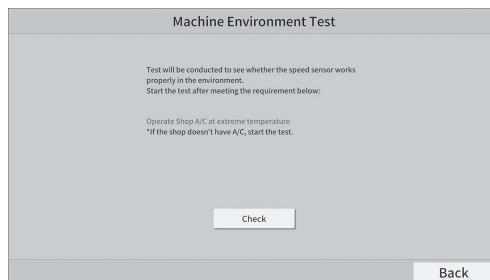

5 - 1 - 3 - 3 Fig. 03

STEP  
3

While it performs checks (5-1-3-3 Fig. 04), wait without touching DARTSLIVE3.

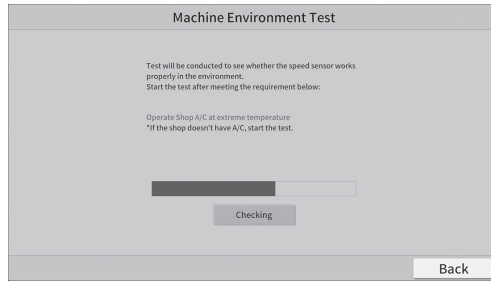

5 - 1 - 3 - 3 Fig. 04

STEP  
4

If it is an appropriate location for the installation, the confirmation window (5-1-3-3 Fig. 05) appears.

If it is an inappropriate location for the installation, the window prompting another location (5-1-3-3 Fig. 06) appears.

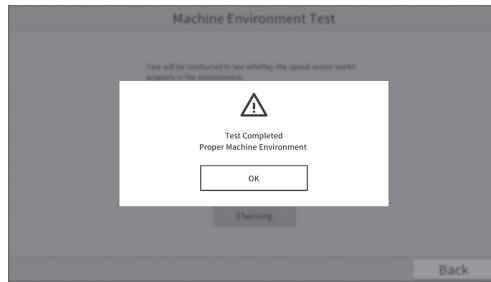

5 - 1 - 3 - 3 Fig. 05

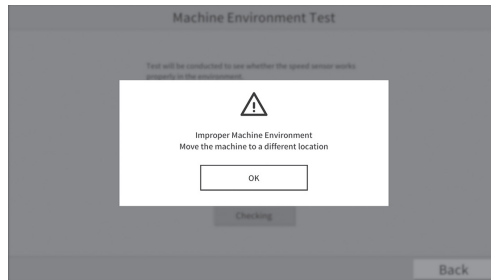

5 - 1 - 3 - 3 Fig. 06

STEP  
5

If it is an inappropriate location, try the following:

**Action to Take :** Move the installation location of DARTSLIVE3 by 5 cm or more, and perform the Machine Environment Test again.



### 5 - 1 - 3 - 4 Card Reader Sensor

You can check whether the card reader is working properly or not. When you insert the card into the card reader, the displayed word "NO CARD" changes to the number of the ID card. When you insert two cards, both "NO CARD" at two positions change.

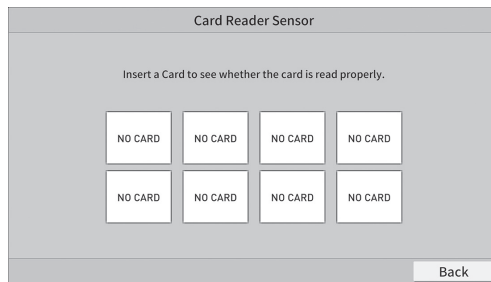

5 - 1 - 3 - 4 Fig. 01

### ■ 5 - 1 - 4 Target

You can perform target display test and membrane switch test.

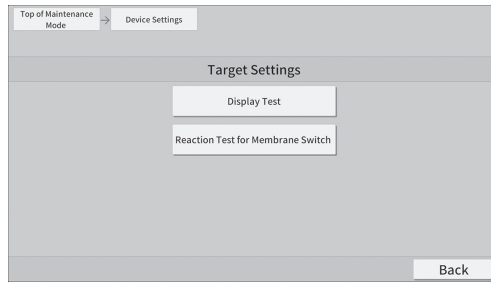

5 - 1 - 4 Fig. 01

**Display Test :** You can perform the display test of the target LED. The target LEDs switch in order of red, green, blue, and white. The display on the touch screen monitor changes accordingly.

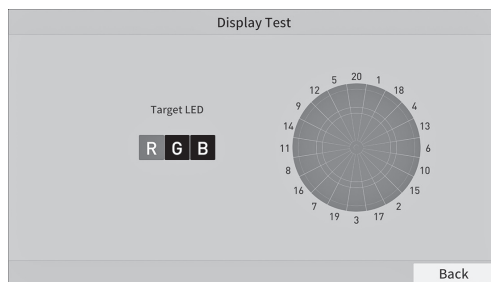

5 - 1 - 4 Fig. 02

**Reaction Test for Membrane Switch :** You can perform reaction test by pressing at each area on the target.

If the positions are displayed on the touch screen monitor when you press the target, the devices and wiring of the input system are normal.

Conduct this test periodically to check that the equipment is functioning properly.

The area from 1 to 20 on the target are divided into S (SINGLE-IN / SINGLE-OUT), D (DOUBLE), and T (TRIPLE).

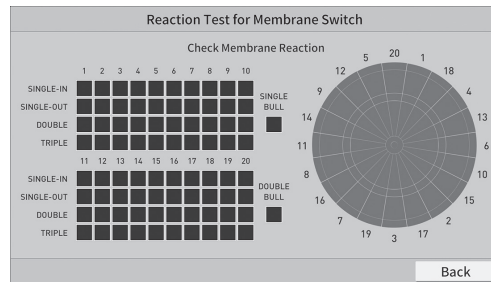

5 - 1 - 4 Fig. 03

### ■ 5 - 1 - 5 Light

- Side LED - Refer to "5-1-5-1 Side LED".
- Standing Navi LED - Refer to "5-1-5-2 Standing Navi LED".
- Card reader LED - Refer to "5-1-5-3 Card Reader LED".
- Number LED - Refer to "5-1-5-4 Number LED".
- Initialize all LED Brightness Settings - Refer to "5-1-5-5 Initialize all LED Brightness Settings".

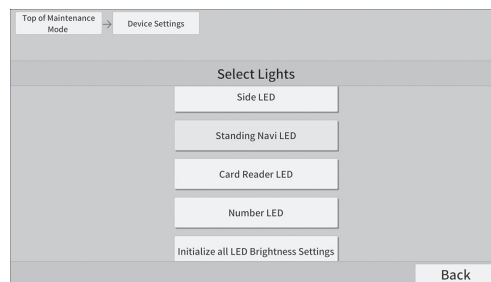

5 - 1 - 5 Fig. 01

## 5 - 1 - 5 - 1 Side LED

You can test the display and adjust the brightness on the side LED.

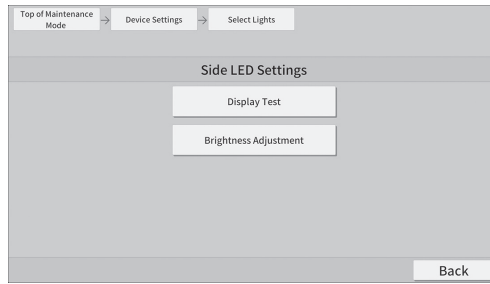

5 - 1 - 5 - 1 Fig. 01

**Display Test :** You can perform the display test of the side LED. The side LED switches in order of red, green, blue, and white. The display on the touch screen monitor changes accordingly.

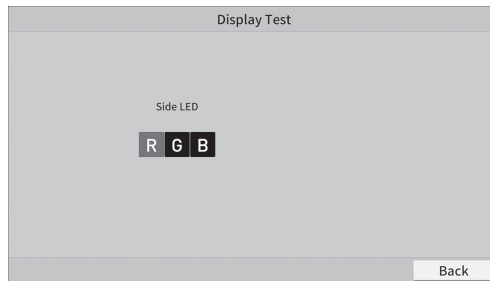

5 - 1 - 5 - 1 Fig. 02

**Brightness Adjustment :** You can adjust the brightness of the side LED. You can adjust it in steps 0 to 3. 0 turns it OFF. The smaller the number, the darker it gets; the larger the number, the brighter it gets.

**Initialization :** It restores the brightness to the factory setting.

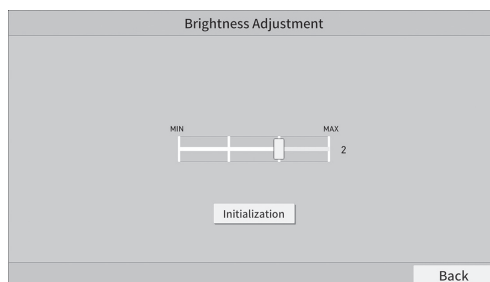

5 - 1 - 5 - 1 Fig. 03

### 5 - 1 - 5 - 2 Standing Navi LED

**Brightness Adjustment :** You can adjust the brightness of the Standing Navi LED. You can adjust it in steps 0 to 20. 0 turns it OFF. The smaller the number, the darker it gets; the larger the number, the brighter it gets.

**Initialization :** It restores the brightness to the factory setting.

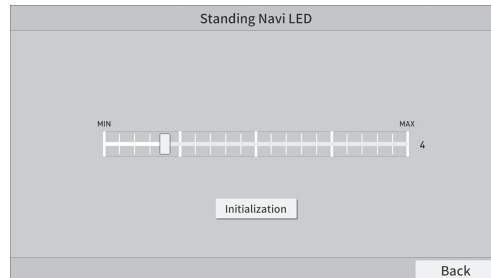

5 - 1 - 5 - 2 Fig. 01

### 5 - 1 - 5 - 3 Card Reader LED

**Brightness Adjustment :** You can adjust the brightness of the card reader LED. You can adjust it in steps 0 to 3. 0 turns it OFF. The smaller the number, the darker it gets; the larger the number, the brighter it gets.

**Initialization :** It restores the brightness to the factory setting.

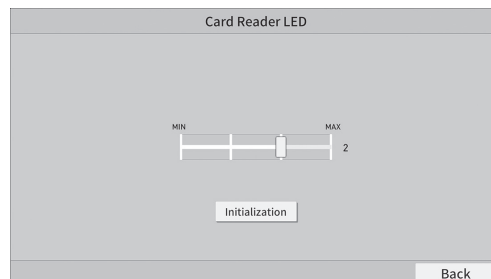

5 - 1 - 5 - 3 Fig. 01

### 5 - 1 - 5 - 4 Number LED

**Brightness Adjustment :** You can adjust the brightness of the Number LED on the target (the board).  
You can adjust it in steps 0 to 3.  
0 turns it OFF.  
The smaller the number, the darker it gets; the larger the number, the brighter it gets.

**Initialization :** It restores the brightness to the factory setting.

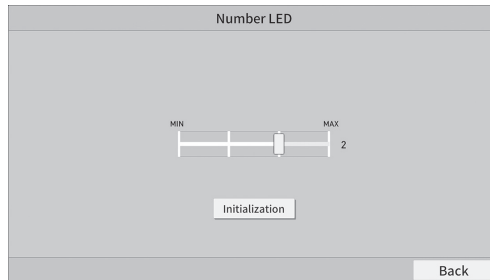

5 - 1 - 5 - 4 Fig. 01

### 5 - 1 - 5 - 5 Initialize all LED Brightness Settings

You can restore all LED brightness adjustments to the factory setting at once.

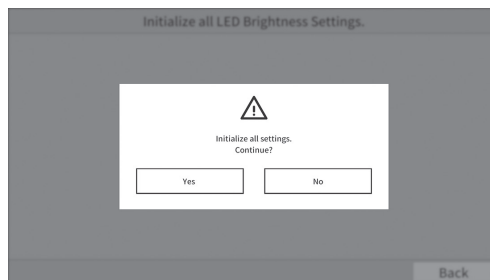

5 - 1 - 5 - 5 Fig. 01

### ■ 5 - 1 - 6 Sound

You can adjust the sound volume.  
You can adjust it in steps 0 to 100.  
0 turns it OFF.  
The smaller the number, the smaller the sound gets; the larger the number, the larger it gets.

**Initialization :** It restores the sound volume to the factory setting.

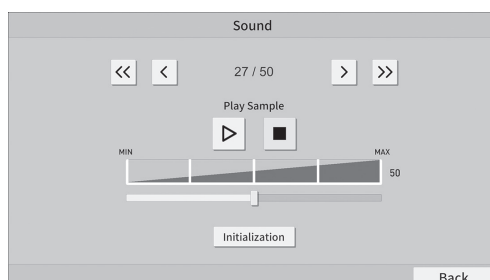

5 - 1 - 6 Fig. 01

## 5 - 2 Coin Credit Administration

You can check and configure various coin credit settings.

- Counter Management - Refer to "5-2-1 Counter Management".
- Insert Coin Settings - Refer to "5-2-2 Insert Coin Settings".
- Coin Chute Credit / Free Play Settings - Refer to "5-2-3 Coin Chute Credit / Free Play Settings".
- Settings for Regular Game Credit - Refer to "5-2-4 Settings for Regular Game Credit".
- Happy Hour Credit Settings / Setting Time - Refer to "5-2-5 Happy Hour Credit Settings / Setting Time".

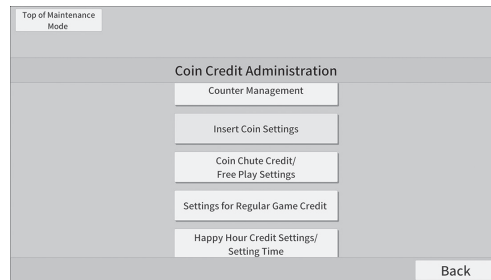

5 - 2 Fig. 01

### ■ 5 - 2 - 1 Counter Management

You can check the items required for counter management, and clear counter values.

- Counter by Credit - Refer to "5-2-1-1 Counter by Credit".
- Counter by Game - Refer to "5-2-1-2 Counter by Game".
- Reset All Counter Administration Data - Refer to "5-2-1-3 Reset All Counter Administration Data".

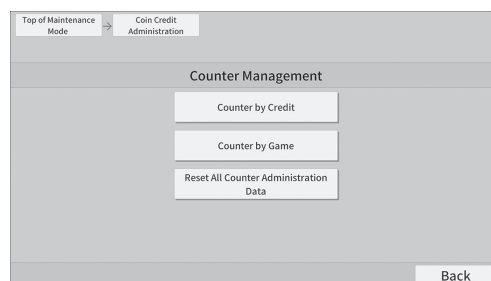

5 - 2 - 1 Fig. 01

### 5 - 2 - 1 - 1 Counter by Credit

You can check the Counter by Credit from the day the machine was started and the number of Counter by Credit from the date the counter was reset.

**Reset :** It resets the counter to zero that has been counted from the day it was last reset until today.

\* You cannot reset the Counter by Credit that has been counted from the day the machine was started.

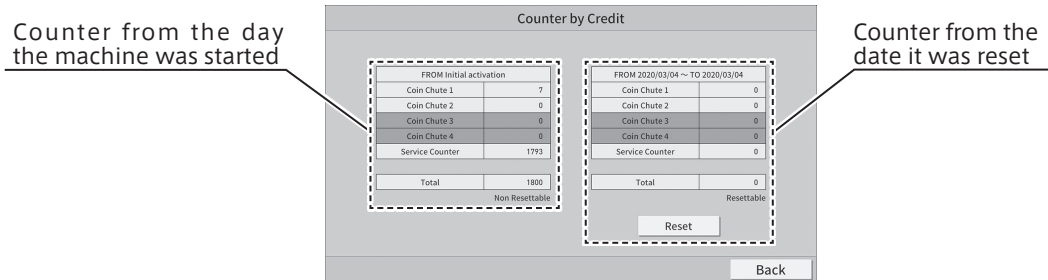

5 - 2 - 1 Fig. 02

### 5 - 2 - 1 - 2 Counter by Game

It displays a list of Counter by Credit that were counted from the last day it was reset until today.

**Play Ranking :** It lists them in order of the Credit.

Those with the same Credit will be ranked in the same order.

**Game :** It lists the games linked to the Play Ranking.

**Credit :** It list the Credit put into the game.

**Reset :** It resets the Counter by Credit to zero that has been counted from the day it was last reset until today.

\* You cannot reset the Counter by Credit that has been counted from the day the machine was started.

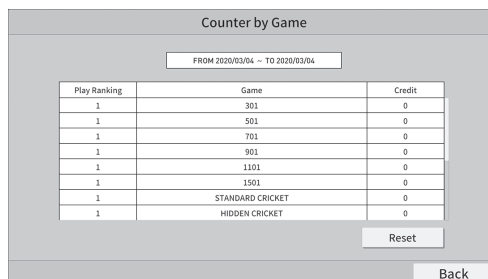

5 - 2 - 1 - 2 Fig. 01

### 5 - 2 - 1 - 3 Reset All Counter Administration Data

You can reset all functions at once which can be reset in both Counter by Credit and Counter by Credit.

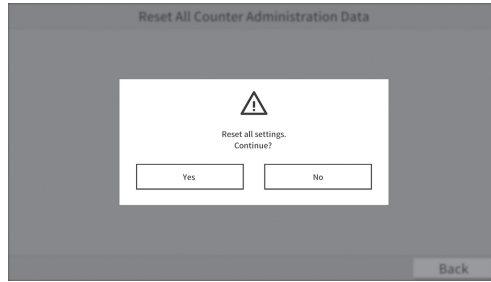

5 - 2 - 1 - 3 Fig. 01

### ■ 5 - 2 - 2 Insert Coin Settings

You can turn ON/OFF the Insert Coin Settings.

\* You cannot configure Insert Coin when Free Play has been turned ON in "Coin Chute Credit / Free Play Settings".

**ON :** It enables the coin chute.

The Credit increases by putting coins into the coin chute.

\* When the Credit is 999, it will automatically be turned OFF.

**OFF :** It disables the coin chute.

When you insert coins into the coin chute, they are ejected to the return slot.

\* You cannot change the setting to ON while the Credit is 999 (5-2-2 Fig. 02).

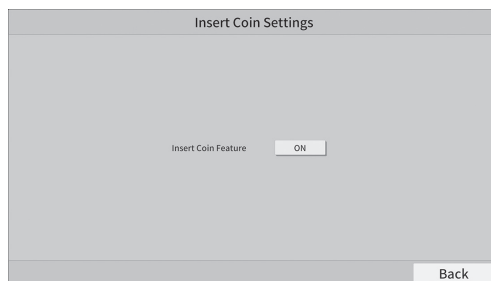

5 - 2 - 2 Fig. 01

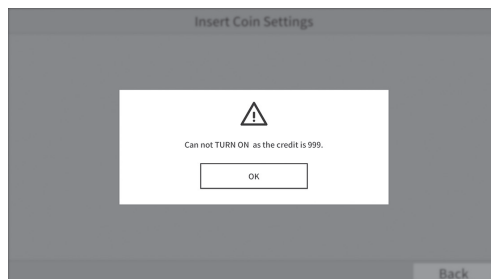

5 - 2 - 2 Fig. 02



### ■ 5 - 2 - 3 Coin Chute Credit / Free Play Settings

**Coin Chute Credits :** You can set the number of credit to increase for each coin inserted.

**Free Play Settings :** You can activate Free Play Settings by turning it ON.

\* It automatically turns OFF Insert Coin Settings while Free Play Settings is enabled. In addition, you will not be able to change the Insert Coin Settings.

\* In some cases you cannot activate Free Play Settings.

**Initialization :** It restores the Coin Chute Credits / Free Play Settings to the factory setting.

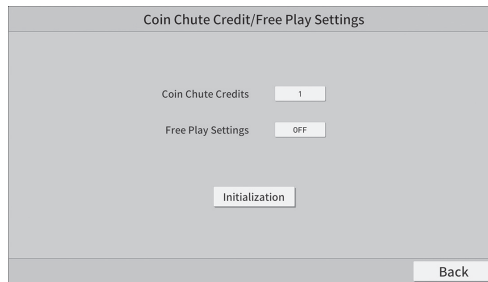

5 - 2 - 3 Fig. 01

### ■ 5 - 2 - 4 Settings for Regular Game Credit

**Credit :** You can change the number of credit for each game between 1 to 5.

**Initialization :** It restores the number of credit to the factory setting.

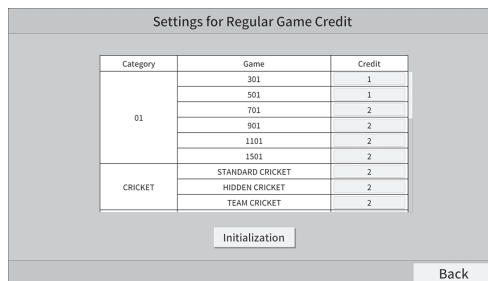

Category	Game	Credit
01	301	1
	501	1
	701	2
	901	2
	1101	2
	1501	2
CRICKET	STANDARD CRICKET	2
	HIDDEN CRICKET	2
	TEAM CRICKET	2

5 - 2 - 4 Fig. 01

### ■ 5 - 2 - 5 Happy Hour Credit / Time Setting

You can configure the credit setting applied while in Happy Hour and the time for Happy Hour.

· Game Credit Settings - Refer to "5-2-5-1 Game Credit Settings".

· Time Settings - Refer to "5-2-5-2 Time Settings".

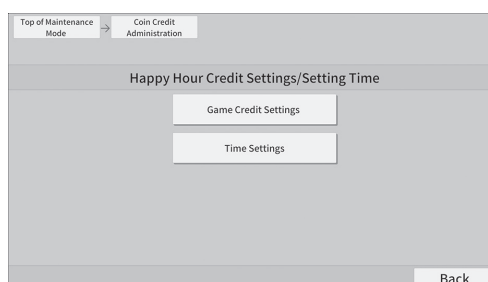

5 - 2 - 5 Fig. 01

## 5 - 2 - 5 - 1 Game Credit Settings

**Settings for Happy Hour Free Play :** You can enable Free Play during Happy Hour by turning this ON.

**Credit Settings for all :** By turning this ON, it will reflect the Credit Settings for all during Happy Hour.

You can change it between 1 to 5 credits.

\* When Credit Settings for all is ON, you cannot configure the number of credit for individual games.

**Number of Credit :** You can change the number of credit for each game between 1 to 5.

\* You cannot change it when Credit Settings for all is ON.

**Initialization :** It restores the number of credit to the factory setting.

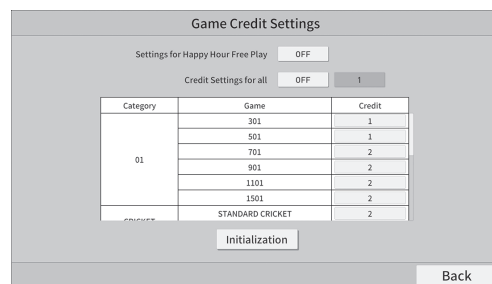

5 - 2 - 5 - 1 Fig. 01

## 5 - 2 - 5 - 2 Time Settings

You can set the day and time of Happy Hour.

When you touch and swipe the time you want to set, it will color the time zone of the set day of the week.

You can cancel it by touching the colored section again.

**Initialization :** By tapping this, you can Initialization the day and time for Happy Hour to the factory setting.

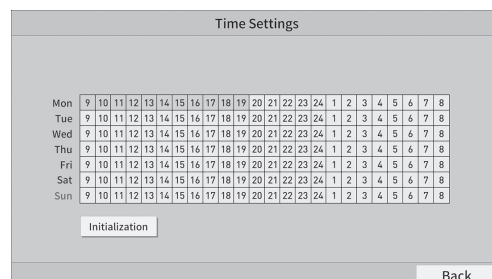

5 - 2 - 5 - 2 Fig. 01

## 5 - 3 Game Settings

You can configure if to display specific games, change the number of rounds and the number of Back to the Prev Player/ Darts Position Correction.

- Settings by Category / by Game - Refer to "5-3-1 Settings by Category / by Game".
- Basic Settings - Refer to "5-3-2 Basic Settings".

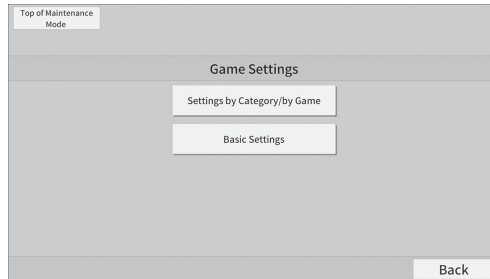

5 - 3 Fig. 01

### ■ 5 - 3 - 1 Settings by Category / by Game

**Show / Hide by Category :** Categories and games that are set to ON appear in the menu.

Categories and games that are set to OFF will not be displayed in the menu.

**Show / Hide by Game :** Games that are set to ON appear in the menu.

Games that are set to OFF will not be displayed in the menu.

**Number of Round Setting by Game :** Games proceed with the set number of rounds.

**Initialization :** It restores the display setting and number of rounds to the factory setting.

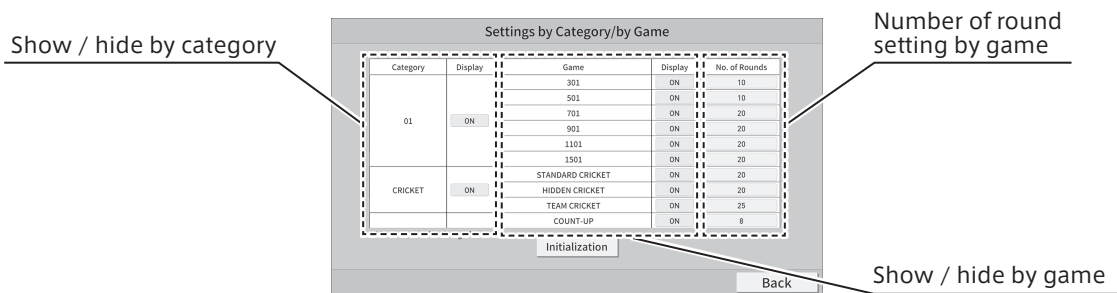

5 - 3 - 1 Fig. 01

### ■ 5 - 3 - 2 Basic Settings

You can change the setting that is common in the games.

#### **Limit on Back to the Prev Player / Darts Position Correction :**

You can limit the number of times to make correction when there is a mistake in dart position.

You can change the setting between 0 to 9 times.

**Initialization :** It restores the limit on number of corrections to the factory setting.

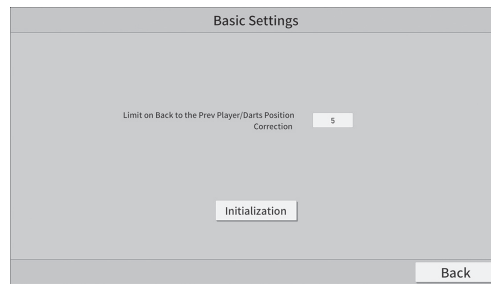

5 - 3 - 2 Fig. 01

## 5 - 4 Advertise Settings

**Advertise Sound Setting :** You can turn ON/OFF the sound of advertise.

\* Some advertise have no sound from the beginning.

\* In some cases, Advertise Sound Setting is not available.

## 5 - 5 Language Settings

You can change the language to use.

\* In some cases, Language Settings is not available.

## 5 - 6 Network Settings

In Network Test on DARTSLIVE3, you can test the status of network operation. In Online Settings, you can change registered shops and cancel the network services.

- Network Test - Refer to "5-6-1 Network Test".
- Online Settings - Refer to "5-6-2 Online Settings".

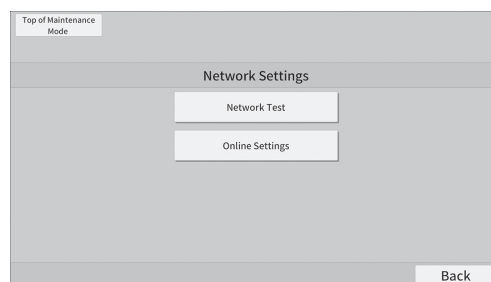

5 - 6 Fig. 01

## ■ 5 - 6 - 1 Network Test

When it is operating normally, it displays "OK" on the item.

When it is having an error, it displays "ERROR" on the item having the error.

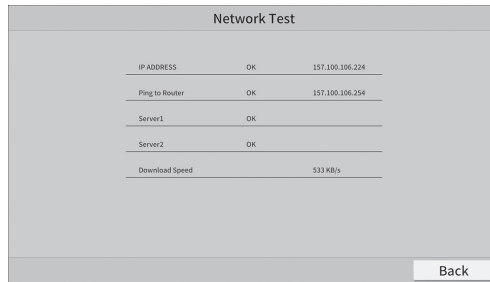

Network Test		
IP ADDRESS	OK	157.100.106.224
Ping to Router	OK	157.100.106.254
Server1	OK	
Server2	OK	
Download Speed		533 KB/s

5 - 6 - 1 Fig. 01

## ■ 5 - 6 - 2 Online Settings

- Change Registered Shops - Refer to "5-6-2-1 Change Registered Shops".
- Cancel Network Service - Refer to "5-6-2-2 Cancel Network Service".

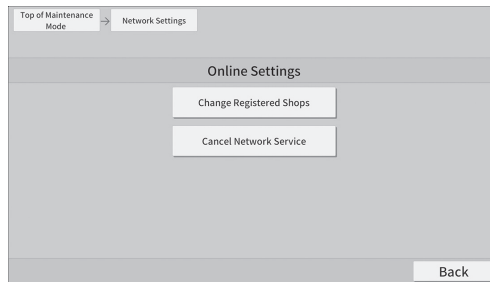

5 - 6 - 2 Fig. 01

### 5 - 6 - 2 - 1 Change Registered Shops

Enter all of the following: "Registered Dealer ID", "Registered Dealer PASS (PIN)", and "Target Shop ID". Tap "All Entered".

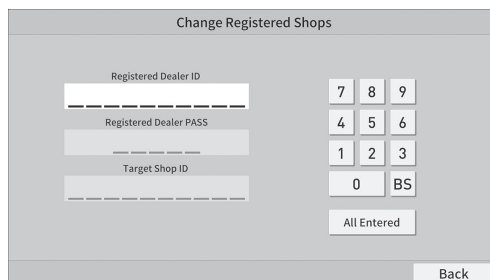

Change Registered Shops

Registered Dealer ID

Registered Dealer PASS

Target Shop ID

7 8 9

4 5 6

1 2 3

0 BS

All Entered

Back

5 - 6 - 2 - 1 Fig. 01

1  
2  
3  
4  
5  
6

It displays names of the dealer, the old shop, and the new shop. Verify the changes. Tapping "Yes" will complete the change of registered shop. (5-6-2-1 Fig. 02)  
After changing the registered shop, DARTSLIVE3 needs to be restarted. Please restart DARTSLIVE3. (5-6-2-2 Fig. 03)



5 - 6 - 2 - 1 Fig. 02

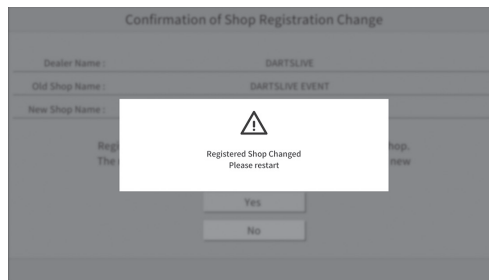

5 - 6 - 2 - 1 Fig. 03

### 5 - 6 - 2 - 2 Cancel Network Service

Enter "Registered Dealer ID" and "Registered Dealer PASS (PIN)". Tap "All Entered".

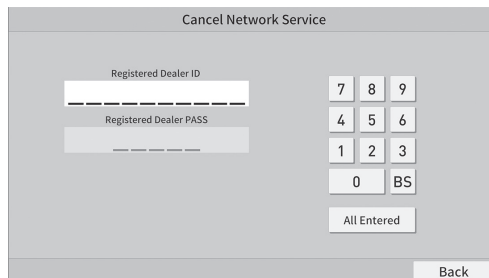

5 - 6 - 2 - 2 Fig. 01

When the final confirmation screen appear, you can cancel the network service by tapping "Yes".

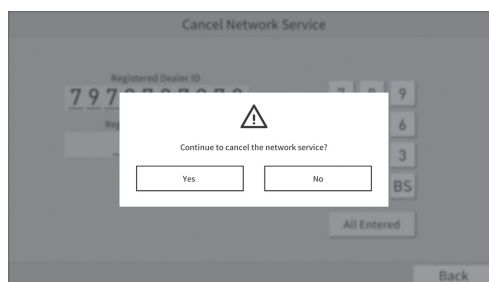

5 - 6 - 2 - 2 Fig. 02

## 5 - 7 Machine Info

It displays information about current settings for network services on the machine.

**Machine ID :** Identification unique to the machine.

**Sub Machine ID :** Sub-identification unique to the machine.

**Shop Name :** Name of the shop where DARTSLIVE3 is installed.

**Date and time :** Current date and time.

\* The time is automatically adjusted when online.

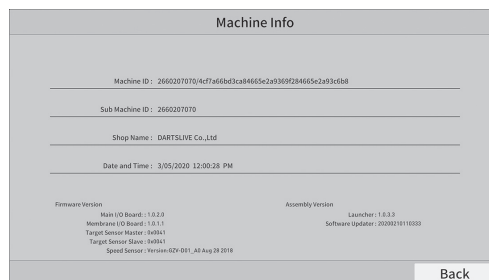

5 - 7 Fig. 01

## 6 Troubleshooting

If the network does not operate normally, take the following steps first.

- \* Before turning off the power of "DARTSLIVE3", be sure to restart the modem and router. Not doing so may clear the stored data.
- \* If the network is operating normally, online symbol appears at the network operation status.

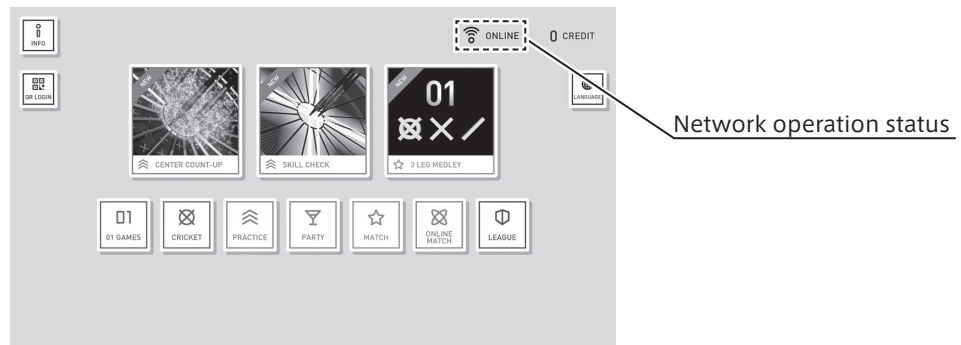

6 Fig. 01



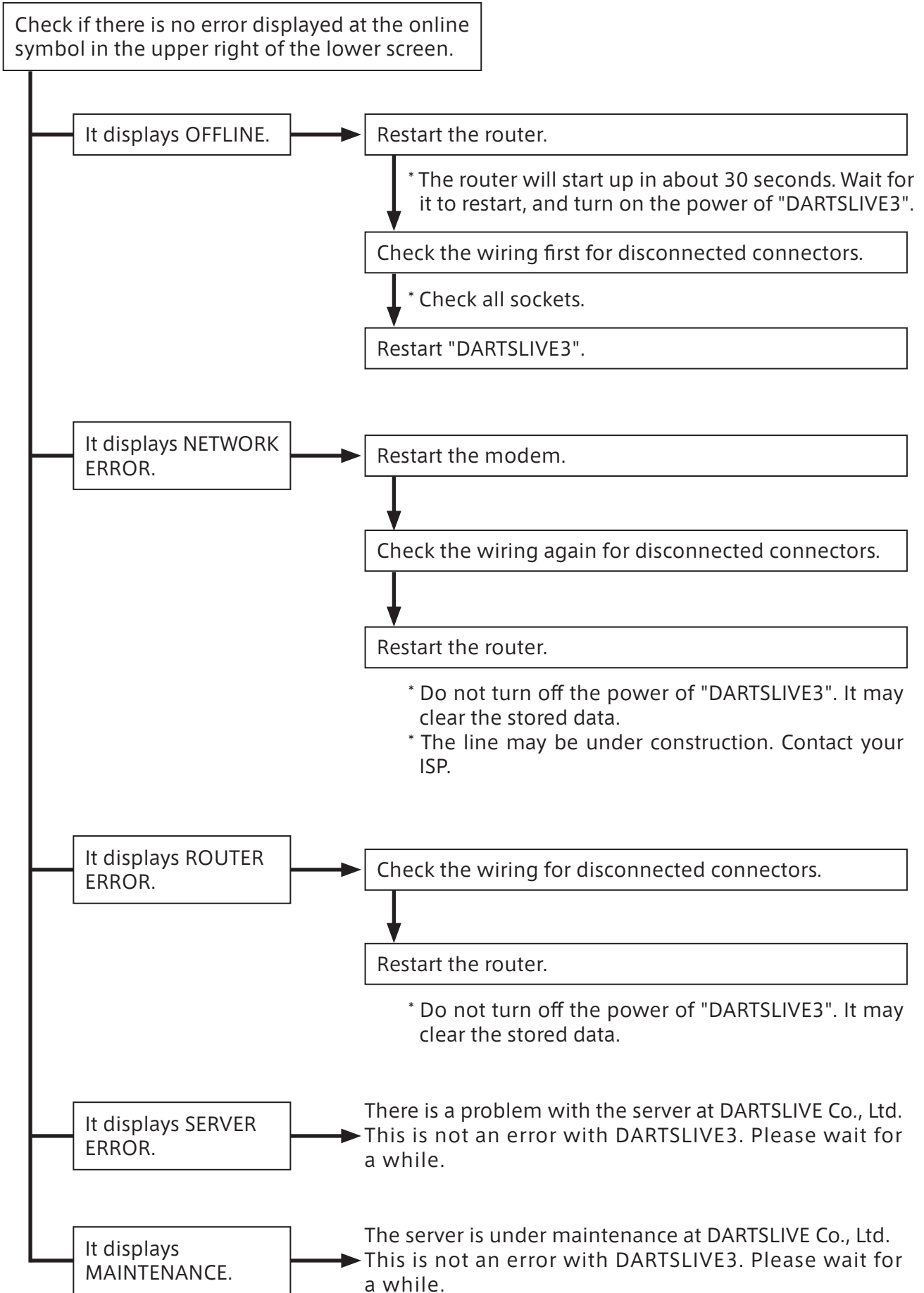

For inquiries regarding networks other than the above, contact your dealer.

## 6 - 1 Overview of Network

### ■ 6 - 1 - 1 Network Structure

The network connection for "DARTSLIVE3" is structured as the following.



6 - 1 - 1 Fig. 01

### ■ 6 - 1 - 2 Supplemental Terminology

**Router** : A device to connect multiple LANs. Installed at a junction connecting multiple LANs, it relays data flowing on the network to other networks.

**LAN** : A computer network connecting multiple computers in the same building.

**HUB** : LAN cable concentrator.

1

2

3

4

5

6

## ■ 6 - 1 - 3 Network Operation Status

At the top right corner on the screen of the "DARTSLIVE3", you can check the status of the network.

Operation status are classified into the following six types.

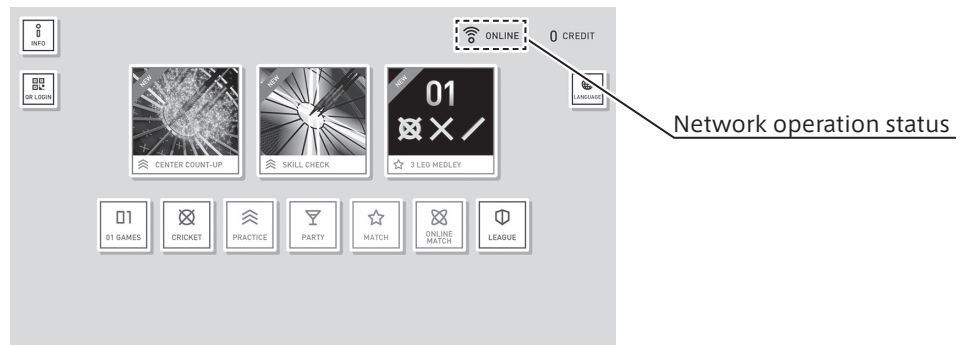

6 - 1 - 3 Fig. 01

### Online :

It is connected to the network and operating normally.

You can see the line speed with the icon.



6 - 1 - 3 Fig. 02

### Offline :

It is not connected to the network.

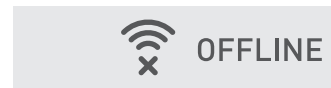

6 - 1 - 3 Fig. 03

### Network Error :

Network is disconnected.



6 - 1 - 3 Fig. 04

### Router Error :

It is not connected to the network because of the router.



6 - 1 - 3 Fig. 05

### Server Error :

The server at DARTSLIVE Co., Ltd. is having an error.

Data is not recorded on the server.



6 - 1 - 3 Fig. 06

### Server Maintenance :

The server is under maintenance at DARTSLIVE Co., Ltd.

Data is not recorded on the server.



6 - 1 - 3 Fig. 07

### ■ 6 - 2 - 1 When it Says OFFLINE

**Cause :** Contact failure or disconnection of power supply or LAN.

The following causes can be considered:

- Cable is disconnected.
- Router is not turned on.
- Router has an error.
- Error around HUB.
- Failure of network cable.
- It is operating without activation. (exceptional case)

**Actions to Take :** Check the following items:

#### < Check Cable and Hub >

→ Check the sockets of the connected devices for disconnected or loose cable.

#### < Check Router >

■ Is the LED indicator on the router lit on?

→ If it is not lit, the router is not powered on. Check the AC adapter.

■ Is the WAN indicator on the router lit on?

→ If it is not lit, the cable between the modem and the router is not connected properly.

Are the cables from the modem and other devices connected to the router's socket for WAN? Are they firmly connected?

Are the cables from the router connected to the modem or other devices? Are they firmly connected?

■ Is the LAN indicator on the router lit on?

→ If it is not lit, the cable between the router and "DARTSLIVE3" is not connected properly.

Is the cable from the router connected to the "DARTSLIVE3"? Is it firmly connected?

Is the cable from the "DARTSLIVE3" connected to the router? Is it firmly connected?

■ Is the DIAG indicator lit on?

→ If it is lit, something is wrong with the router. Restart the router.

■ If none of the above apply

→ Turn off the power and start it up again.

If it still does not operate online, contact your dealer.

## ■ 6 - 2 - 2 When it Says ERROR

It displays error when it is turned on.  
Or, it displayed an error while it was running online.

**Cause** : It is either contact failure of LAN, Internet connection failure, or access restriction.

**Actions to Take** : Type of error is displayed on the left side of the error display. Take actions according to each type.

### < ROUTER ERROR >

You have an error in network line. You need to take the same action as when it is offline.

#### ■ Is the LED indicator on the router lit on?

→ If it is not lit, the router is not powered on. Check the AC adapter.

#### ■ Is the WAN indicator on the router lit on?

→ If it is not lit, the cable between the modem and the router is not connected properly.

Are the cables from the modem and other devices connected to the router's socket for WAN? Are they firmly connected?

Are the cables from the router connected to a modem or other devices? Are they firmly connected?

Are the power of the modem and other devices connected?

#### ■ Is the LAN indicator on the router lit on?

→ If it is not lit, the cable between the router and "DARTSLIVE3" is not connected properly.

Is the cable from the router connected to the "DARTSLIVE3"? Is it firmly connected?

Is the cable from the "DARTSLIVE3" connected to the router? Is it firmly connected?

#### ■ Is the DIAG indicator lit on?

→ If it is lit, something is wrong with the router. Restart the router.

### < NETWORK ERROR >

You have an Internet connection failure due to ISP (Internet service provider) or telephone line.

Check the line first. (This can be due to construction or maintenance on the line.)

After a certain period of time, it automatically shifts to online mode when the line is restored.

### < SERVER ERROR >

**Cause** : There is a problem with the server at DARTSLIVE Co., Ltd. This is not an error with DARTSLIVE3.

**Actions to Take** : Keep it operating offline. It will automatically switch to online operation when the actions on the server is completed.

### < When it says MAINTENANCE >

**Cause** : The server is under maintenance at DARTSLIVE Co., Ltd.

**Actions to Take** : Server maintenance is not an error. "DARTSLIVE3" usually shuts down the network for about one hour from 6:30 a.m. (Japan Standard Time) on the first day every month due to server maintenance.

You cannot execute any procedure or use service using the network, such as online operation and activation operations. At such times, leave it operating offline. It automatically switches to online operation after the maintenance is completed.

For general inquiries:

## **DARTSLIVE Support Desk**

<https://www.dartslive.com>

\* Please note that this support desk is not accepting inquiries regarding the machine and the parts.

Please contact the retailer for such inquiries.

## **DARTSLIVE Co.,Ltd.**

Sumitomo Fudosan Osaki Garden Tower, 1-1-1 Nishi-Shinagawa, Shinagawa-ku,  
Tokyo 141-0033, Japan

<http://www.dartslive.com/corp/jp/contact/>

facsimile +81-50-3153-7982

For basic troubleshooting, go to the following "Product Support Page".



<http://www.dartslive.jp/info/support/>

The information herein contained are as of June 2020.

**1st edition**

June 2020